

**Regia Anglorum**

# **AUTHENTICITY GUIDE**

**2015**

## © Regia Anglorum 2015

*The intellectual property of this document is vested in Regia Anglorum. The whole or parts may be reproduced by paid-up members of the Society for onward transmission to other members of Regia Anglorum for use in the context of a set of regulations. Parts of it may be reproduced for the purposes of review or comment without permission, according to the Laws of Copyright.*

### Document Information

Written by	Gavin Archer
with contributions by	Stephen Etheridge, Gary Golding and Louise Archer
Illustrations	Gavin Archer, Matt Steward (Kit Guide Warriors), Alan Tidy, Stephen Shepherd, Gary Golding
Cover Design	Alison Offer (Photos) and Roland Williamson
Acknowledged for their advice and assistance	Allan Tidy, Andrew Nicholson, Becka Griffiths, Catherine Stallybrass, Clare Williams, Dave Anderson, Ian Uzzell, Jon Smith, Hazel Uzzell, Helen Bowstead-Stallybrass, Kat Dearden, Kim Siddorn, Lauren Makin, Liz Daborn, Liz Walsh, Louisa Sanderson, Martin Williams, Mike Everest, Roland Williamson, Sarah Doyle, Stephanie James, Stephen Shepherd, Stuart Davies, Stuart Makin, Tom Gibson, Tim Jorgensen.

### Picture credits

All illustrations are by Gavin Archer except for:

#### The Regulations

**p.6** Walrus [Regia Anglorum]; **p.7** Spoon [World of the Vikings CD-ROM, Cambridge-Hitachi, 2003]; **p.10** Lords in Judgement ['Hexateuch', Cotton Claudius B IV, British Library]; **p.11** Viking fury hat [Almgren, B. 'The Viking' 1966]; **p.11** Lord's Covenant ['Hexateuch', Cotton Claudius B IV, British Library]; **p.11** Apollo 15 [www.wikipedia.org]; **p.14** Bayeux Tapestry [Stothard, Charles 'Vetusta Monumenta, vi', 1819]; **p.14** Coins [Gary Golding]; **p.16** Thor [Arthur Rackham, 1900]

#### Women's Clothing

**p.18** Under Tunic [Regia Anglorum]; **p.19** Woman in generic kit [Alan Tidy]; **p.21** Headscarf [Almgren, B. 'The Viking' 1966]; **p.21** Headscarf [www.Regia.org]; **p.21** English cap [www.Regia.org]; **p.21** Simple small Wimple [www.Regia.org]; **p.21** Hood [Stephen Shepherd]; **p.22** Palla [Stuttgart, Württembergische Landesbibliothek]; **p.22** Queen Ælfthryth [British Library]; **p.22** Pouch and bag [Steve Shepherd]; **p.23** Shoes [Steve Shepherd]; **p.24** Viking Woman [Arne, T. 'Das Bootgräberfeld von Tuna in Alsike Uppland' 1934]; **p.25** Viking cap [www.Regia.org]; **p.25** Headscarf [www.Regia.org]; **p.26** Norman Dress (Life of St Aubin) [Bibliothèque Nationale de France]; **p.26** Norman Bliaut sleeves Judith of Flanders [New York, Pierpont Morgan Library]; **p.27** Barrette, Eleanor of Aquitaine [Internet]; **p.27** Peasant [Koninklijke Bibliotheek]

#### Men's Clothing

**p.29** Long tunic (St. Albans Psalter) [Hildesheim, St. Godehard]; **p.30** Under Tunic [Regia Anglorum]; **p.30** Man in generic kit [Alan Tidy]; **p.31** Hose & Brais [Regia Anglorum];

**p.33** Hood and Skull cap [Regia Anglorum]; **p.34** Pouch and bag [Steve Shepherd]; **p.34** Shoes [Steve Shepherd]; **p.34** Comb [Gary Golding]; **p.36** Proto Romanesque Tunic [British Library]; **p.36** Bliaut Tunic [Dijon, Bibl. Municipale]; **p.36** Dalmatic Tunic [Jewish Antiquities]; **p.37** Peasant [Koninklijke Bibliotheek]; **p.37** Frankish Prince [Paris BNF]; **p.38** Straw Hat (Eadwine Psalter) [Cambridge Trinity College]; **p.38** Face Mask [Hagg, Inga 'Ausgrabungen in Haithabu, Die Texttilfunde', 1984]; **p.39** Birka Pouch [Ardwidsson, Greta 'Birka II:1, der Gräberfunde', 1984]; **p.40** Woman and Child [City of Bayeux]

#### Warriors

**p.41** Warrior (Life of St Aubin) [Bibliothèque Nationale de France]; **p.44** Hexateuch, [Hewitt, John. 'Ancient Armour and Weapons in Europe', 1885]; **p.47** Gokstad Shield [Nicolaysen, 'The Viking Ship discovered at Gokstad in Norway', 1882]; **p.47** Shield designs [Steve Shepherd]; **p.48** Harley Psalter [Hewitt, John. 'Ancient Armour and Weapons in Europe', 1885]; **p.49** Canterbury window [Healey 1996, Life in the Viking Age]; **p.50** Bayeux Tapestry [Worssae 1852]; **p.50** Martyrdom of Thomas Becket [Hewitt, John. 'Ancient Armour and Weapons in Europe', 1885]; **p.51** Virtue [British Library]; **p.52** Great Polish Helm [Kirpichnikov, Anatolij 'Drevnerusskoe Oruzhie III' 1971]; **p.52** Allowable Knotwork [Kershaw, Jane 'Viking Identities' 2013]

#### The Wic

**p.58** Men working ['Hexateuch', Cotton Claudius B IV, British Library]; **p.59** Bayeux Tapestry [Stothard, Charles 'Vetusta Monumenta, vi' 1819]; **p.61** Swords [Regia Anglorum]

*All image copyrights are held by their respective source. Their use in this publication is under the assumption of fair usage. If you are the copyright holder for any of these images and would like them removed from this publication, then please contact Regia Anglorum.*

*All other images are copyright Gavin Archer and may be used in any Regia Anglorum publication.*

[Revision: C]

# Contents

MEMBERS OF THE AUTHENTICITY TEAM	4	NORMAN WARGEAR	50
AN INTRODUCTION	5	ANGEVIN KNIGHTS	50
A WORD FROM THE WALRUS	6	WOMEN PORTRAYING MALE COMBATANTS	51
A SUMMARY OF AUTHENTICITY CHANGES	6	COMBATANTS RETURNING TO THE WIC	51
HOW ITEMS BECOME 'UNACCEPTABLE'	7	RESTRICTED WAR GEAR	52
<b>THE REGULATIONS</b>	<b>8</b>	<b>PORTRAYING SOCIAL RANK</b>	<b>53</b>
AN EXPLANATION OF TERMS	8	THE BOUND	53
THE CODE OF LAW	10	THE FREE	54
AUTHENTICITY PROVENANCE	11	THE NOBILITY	55
CONTACTING THE AUTHENTICITY TEAM	12	APPROXIMATE EQUIVALENT RANKS	56
THE ROLES OF THE AUTHENTICITY TEAM	12	<b>THE WIC</b>	<b>57</b>
AUTHENTICITY CHECKS	13	NEW FOR 2015	57
DISPUTES	14	TENTS	57
AUTHENTICITY CHECKS AT LOCAL EVENTS	14	OTHER ITEMS	58
<b>GENERAL DO'S AND DON'TS</b>	<b>15</b>	BATTLEFIELD AUTHENTIC	59
GENERAL RULINGS FOR ALL CLOTHING	15	<b>PREVIOUS AUTHENTICITY RULINGS</b>	<b>60</b>
ITEMS THAT ARE ALWAYS 'UNACCEPTABLE'	16	<b>THE KIT GUIDES</b>	<b>63</b>
SOME SEWING TERMS	17	GENERIC CLOTHING—ALL PERIODS (793–1215AD)	65
<b>WOMEN'S CLOTHING</b>	<b>18</b>	WOMEN'S CLOTHING—VERY EARLY (793–899AD)	67
NEW FOR 2015	18	MEN'S CLOTHING – VERY EARLY (793–899AD)....	69
WOMEN'S GARMENTS	18	WARGEAR – VERY EARLY (793–899AD).....	71
POOR WOMEN'S HEAD COVERINGS	21	WOMEN'S CLOTHING - EARLY (900–979AD) .....	73
WOMEN PORTRAYING MEN	23	MEN'S CLOTHING - EARLY (900–979AD) .....	75
VIKING WOMEN	24	WARGEAR - EARLY (900–979AD) .....	77
NORMAN WOMEN	26	WOMEN'S CLOTHING - MID (980–1041AD).....	79
ANGEVIN WOMEN	27	MEN'S CLOTHING - MID (980–1041AD).....	81
RESTRICTED WOMEN'S CLOTHING	28	WARGEAR - MID (980–1041AD).....	83
<b>MEN'S CLOTHING</b>	<b>29</b>	WOMEN'S CLOTHING - LATE (1042–1079AD) .....	85
NEW FOR 2015	29	MEN'S CLOTHING - LATE (1042–1079AD) .....	87
MEN'S GARMENTS	30	WARGEAR - LATE (1042–1079AD) .....	89
VIKING MEN	35	WOMEN CLOTHING—VERY LATE (1080–1179AD)	91
NORMAN MEN	36	MEN'S CLOTHING – VERY LATE (1080–1179AD) .	93
ANGEVIN MEN	37	WARGEAR – VERY LATE (1080–1179AD).....	95
RESTRICTED MEN'S CLOTHING	37	WOMEN'S CLOTHING—ANGEVIN (1180–1215AD)	97
<b>CHILDREN</b>	<b>40</b>	MEN'S CLOTHING – ANGEVIN (1180-1215 AD) ...	99
<b>PETS AND LIVESTOCK</b>	<b>40</b>	WARGEAR – ANGEVIN (1180-1215AD) .....	101
<b>WARRIORS</b>	<b>41</b>	FOOD - (ALL PERIODS) .....	102
THE WARRIOR SYSTEM	41	WIC EQUIPMENT - (ALL PERIODS).....	105
NEW FOR THE 2015 SEASON	43	<b>TIMELINE</b>	<b>107</b>
WARGEAR	44		
VIKING WARGEAR	50		

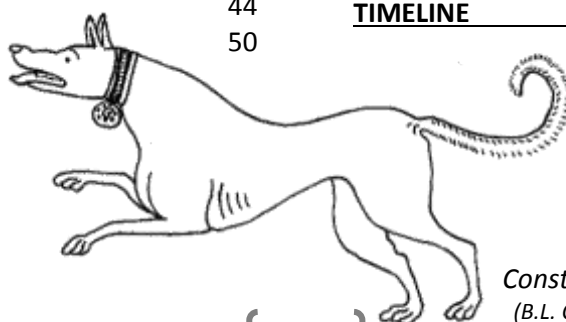

Constellation of Sirius  
(B.L. Cott. Tib. B Vf.39v)



# Members of the Authenticity Team



*Equine*

(B.L. Cotton Cleopatra C VIII  
"Psychomachia" f.15v c.1000AD)

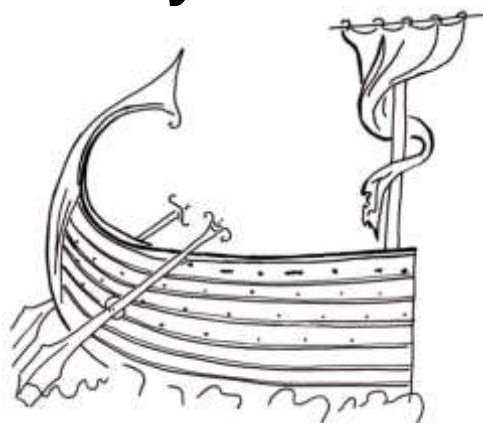

*Maritime*

(B.L. Harley 2506 "Aratea" f.42r  
c.980-1000AD.)

## Authenticity Officer (AO)

Gavin Archer [authenticity@regia.org](mailto:authenticity@regia.org)

## Authenticity Deputies

Andy Nicholson

Clare Williams

Gary Golding

Helen Bowstead-Stallybrass

Louisa Sanderson

Louise Archer

Jon Smith

Kat Dearden

Sarah Doyle

Steve Etheridge

Stephen Shepherd

Stuart Davies



*Military*

(B.L. Tiberius C VI f.9r  
c.1050AD)



*Wic*

(B.L. Cleopatra C VIII f.5v  
c.1000AD)



*Missiles*

(B.L. Galba A XVIII f.14r  
c.939AD)



*Construction*

(B.L. Royal 15 A XVI f.84r  
c.1025-1050AD)



*Ecclesiastical*

(B.L. Harley 603 "Psalter" f.29v  
c.1050-1075AD)

## An Introduction

This year's AO Guide feels a long time in the making, having been kick started with the presentation at Islip in January 2014 and it is with some relief that for this year the process has finally come to an end. As always this document remains unfinished and far from what I'd hoped to achieve. Many things are still missing and others only mentioned briefly. To address these shortfalls it still remains my intention to publish another revised and expanded AO Guide for 2016.

Regia is always ambitious, especially when it comes to its aim of recreating 423 years of Saxon and Norman history more accurately than anyone else. Britain changed considerably during Regia's period, 793-1215AD, both socially and materialistically. Fashions changed then, just as they do today, all be it at a slower pace, with high status clothing looking 'old fashioned' after 50 years or so.



*Anglo-Saxon Tent*  
(British Lib., Harley 603 f.33r c.1125-1150AD)

To make all this even vaguely manageable the 423 years that we re-enact has been broken into six periods. Please keep in mind it is not Regia's intention that members need to attain six sets of kit. Every member should however own a set of generic kit, a set of clothing that can be used for all periods. I'd hope that over time members will also attain more period specific items which helps Regia to look and feel different when representing people from different times.

I would like to thank the many people who have helped create this document. This document has benefited from their diverse knowledge of fashion, warfare and everyday items and without their valuable contributions this document would never have been.

The big changes for this year are the inclusion of image plates for women and men for all six of Regia's periods. Hopefully seeing images of the fashions and jewellery for each period will assisting members in making sense of the corresponding tables. The other change is the inclusion of 'AO Special Mention' boxes. These are mainly concerned with encouraging people to adopt more accurate kit and are not intended to be rulings.

I've also included a bit about two-handed spears. This should come as no surprise to anyone who knows me as I've been banging this particular drum for a number of years. My eventual aim is to see most warriors using one-handed spears and to see the numbers of two-handed spears reduced on the Regia battlefield to only a few a side, and then only in the hands of rich professional warriors. I do however appreciate that this will take many years to achieve.

As in previous years the AO Team is happy to discuss anything found in the AO Guide. If you think we've got something wrong, please do let us know.

I hope you find this document helpful.

*Gavin Archer*  
*Authenticity Officer*

The Authenticity Team can be contacted by:

- Posting your query on the 'Regia Members Info' Facebook group – please clearly mark the post as 'Authenticity Query' or tag one of the Authenticity Team in your comment.
- Posting on the Regia egroup – please clearly mark the subject line as 'Authenticity Query'
- Sending an email to [authenticity@regia.org](mailto:authenticity@regia.org)

## A Word from the Walrus

Accurate portrayal is at the very heart of what we do and when you put on your kit, you become an immediate advert for how seriously members of Regia Anglorum take their hobby. Whether you are just starting out and buying cloth at a market stall or an expert commissioning a stitch-perfect cloak, accurate in the choice of rare breed sheep, type of weave, dyestuff and stitch count, your choices either drive us all forward or slow us down. Don't ever think that no-one really cares - because they do.

*Kim Siddorn  
Eolder*



Senex Odobenus Rosmarius

### A Summary of Authenticity Changes

*For a more detailed review of the following changes see pages 18, 29, 43-44 & 57.*

#### **New Allowed items from 1<sup>st</sup> January 2015**

1. Mail shirts that come to just below the belt but do not necessarily cover the groin for events before 980AD. (see page 43)
2. Men's tunics may now end up to 5cm (2") above the knee when belted and rucked. (see page 29)
3. Women portraying POOR status may now wear a dress that ends mid forearm and mid shin. (see page 18)

#### **New Unacceptable items from 1<sup>st</sup> January 2015**

1. No long tunics (man dresses) before 1042AD. (see page 29)
2. No tunic neck facings over 8cm (3") wide before 1042AD. (see page 29)
3. No single-piece blacksmith (Viking women's style) knives. (see page 57)
4. No mail covered gloves. (see page 43)

#### **New Proposed Unacceptable items from 1<sup>st</sup> January 2016**

*If you have any fresh evidence in support of Regia members continuing to use these items please send it to the Authenticity Team. Remember, these can still be used next year (2015) and will only start to be phased out in 2016. **They will not be fully Unacceptable until 2017.***

1. No one piece garments. All tunics and dresses must be made with separate arms and gores in the skirts. (see page 29)
2. No two-handed spear-head blades under 20cm (8") on spears longer than 7'. (see page 44)
3. No Hadseaxes with blades over 25cm (10") after 900AD. (see pages 42 & 43)

## How items become 'Unacceptable'

Items are being continually researched and re-evaluated as new evidence comes to light. As it is Regia Anglorum's wish to be the most authentic society recreating our period of interest, members need to accept that their kit will have to undergo periodic improvement. To assist in achieving Regia's aim it is the AO Team's intention to publish a revised AO Guide every December.

1. Items will only ever move by one column in the Event Kit Guides each year. So for instance an item that is currently classed as 'Optional' *could* become classed as 'Allowable' next year and 'Unacceptable' the year after.
2. Any item that is under consideration of being reclassified as 'Unacceptable' will always be put on 12 months' notice for discussion and presentation by the membership. New rulings will never just happen at an event.
3. Once an item is officially classed as 'Unacceptable' a process of removal will take place. In the first year reminders and warnings will be issued. In the second year final warnings and demands for the removal of the item will be given.

### ***To Ban a Spoon!***

#### ***A hypothetical example for reclassifying spoons as Unacceptable***

Just to be clear we are not making spoons Unacceptable or even thinking about it!  
(well, not this year anyway...)

April  
2015

- An issue is raised about the evidence for spoons and brought to the AO Team's attention.

October  
2015

- The AO Team review any AO issues raised during the season. The evidence for spoons is reviewed and considered to be lacking and it is agreed that spoons should be reclassified as 'Unacceptable'.

December  
2015

- The updated AO Regs are published. Members now have 12 months to present new evidence in support of spoons. At this stage spoons are not banned.

December  
2016

- As no new convincing evidence is presented. Spoons are reclassified as 'Unacceptable'. The 12 month removal period begins. Spoons can still be used for the next year but should be phased out.

January  
2018

- Spoons are now Unacceptable and must not be used in Regia.

*A spoon made of yew from Dublin*

# The Regulations

## An Explanation of Terms



*Queen Emma in a  
Norman Style Dress  
(B.L. Add. 33241 f.iv c.1050AD)*

The following terms are used throughout this document:

### **Regia Anglorum**

Is hereafter referred to as 'Regia' or 'the Society' in this document.

### **Event**

Any occasion where members of Regia perform in front of the public or for the media is classed as an event. The same standard of Regia authenticity applies to all events.

### **Authenticity Team**

This consists of those members of Regia that have been asked to help maintain the society's high standards of authenticity. It includes the Authenticity Officer, Authenticity Deputies, Authenticity Assistants and Authenticity Specialists. Together they make and enforce Authenticity decisions.

The Authenticity Team works in co-ordination with those officerships that have a cross-over with authenticity such as Living History Co-ordinator, Master at Arms, Ecclesiastical Officer, Missiles Officer and Equestrian Officer as well as their deputies and assistants.

### **English**

The term English is preferred over that of Anglo-Saxon or Saxon as these latter terms fit better when describing the migration period whereas the term English was used in contemporary writings from the 10<sup>th</sup> century onwards. It is sometimes written as 'Englisc' which is the Old English way of writing the term, although it is still pronounced as the modern equivalent. Only English characters may use items labelled as '[E]' in the Event Kit Guides.

### **Viking**

The term Viking is used to include all those people from Denmark and Norway as well as those from Norse settled Scotland, Ireland and England. It also includes those people from Sweden and the rest of the Baltic area, although it is hoped that members would choose to avoid basing their kit on finds from these areas except for special events cleared by the AO first. Only Viking characters may use these items labelled as '[V]' in the Event Kit Guides.

### **Norman**

The term Norman is used for any European fashion items that were introduced into England after 1041AD. Items labelled as '[N]' in the Event Kit Guides are not necessarily from Normandy and may be from other European sources such as Frisia or Germany.

### **Encouraged (Very Common)**

These are the items that the Authenticity Team wants to encourage Regia Members to display. Items classed as Encouraged have either numerous provenances or come from well researched interpretations. You should aim to have the majority of your kit from this column.



## Optional (Less Common)

These items are also well provenanced or researched but it is felt that they were less common in the period than those items classed as Encouraged. You should aim to only have some items of your kit from this column.

## Allowable (Interpreted or Rare)

Items in this column are either authentic but not in this period, are rare being based on only one or two provenances, are based on dubious or contentious interpretations or are simply allowed to make our lives during events easier. Ideally you should have very little kit from this column. Items in the Allowable column are much more likely to be banned in the future than other items, although this is by no means a certainty. Those further qualified as 'Restricted' [R] in the event kit guides are usually culturally specific and certain criteria must be fulfilled before they can be used.

## Unacceptable

These items are not allowed to be used by members of Regia during the stated periods at events. Regia Members must not display any item classed as Unacceptable at an event. All modern clothing and equipment is considered Unacceptable by default.

## RICH

To have an item of kit that has been designated as RICH you must be wearing the appropriately corresponding kit. For example a RICH English man would have high quality embroidery whereas a RICH Viking would have silver armbands. The kinds of people who would be RICH in our period would be Thegns or above. Remember we cannot all portray the RICH and it is estimated that only a small minority of the population would have been in this category.



*The Poor and Crippled.*  
(Camb. Corus Christi MS 23 "Psychomachia"  
f.30r c.1000AD)

## POOR

Portraying the POOR in our period is fraught with difficulty as we have very few contemporary references and so much needs to be inferred. Just like when portraying a RICH person a member who wishes to portray someone from the lower ranks of society should strive to keep their kit consistent. The POOR includes both the free and unfree and would have been a significant proportion of the population.

## Generic Kit

Generic kit (sometimes called basic kit) is a term applied to a generic set of clothing that is acceptable throughout Regia Anglorum's periods of interest and for all the ethnic groupings that we portray. All members should have a set of generic kit available at every event.

## Restricted Kit

There are some items that are allowed but only if certain other prerequisites are met. They are labelled [R] in the Event Kit Guides. Items can fall into this category for many reasons but the intention is to limit their number while still allowing a few examples within the society.

Be warned these items run a higher than normal risk of being banned. Failure to adhere to the exact letter and intention of these rulings will mean that you will be asked to remove the said item from display.



## The Code of Law

The following three extracts are taken from the 'Code of Law' version 6.

### 2. Aims and Objectives

- i. Regia shall be a non-religious, non-political and non-profit-making organisation
- ii. It shall recreate the society of the British Isles and their near neighbours in the period c. 950-1066 AD as authentically as practicable
- iii. It shall enable these recreations to inform, educate and entertain the general public.

### 2B The Responsibilities of the Authenticity Officer (AO)

- iv-b. He shall be responsible for the overview of the authentic portrayal of the life and times of the people who lived in and visited the Islands of Britain in the Society's general period of interest. He shall at all times ensure that a balance of portrayal is achieved so as not to make exceptional examples from the period the norm.
- iv-c. He shall make it his concern to augment the Society's corporate knowledge regarding the visual appearance of the peoples of these Islands and their near neighbours in Northern Europe and thus maintain and constantly improve the Society's image at events.
- iv-d. He shall be responsible for encouraging and advising other Society Officers who may have a particular interest and the membership in general regarding all aspects of authenticity of dress, weapons, armour and other equipment, behaviour and attitude.
- iv-e. He shall be prepared to enforce his decisions if it should become necessary at events. He shall have the power of veto over any matter regarding authenticity.

### 3C The Responsibilities of the Membership

- i. It is the duty of the individual member, guided primarily by the leadership of his local group, and then by the relevant Society Officers (and their Deputies) to ensure that any items of clothing and/or equipment intended for public display at any Event are:
  - a. safe in their construction and use (under the relevant regulations of the Society Officers) and
  - b. authentic for the display, bearing in mind the location and published dateline (if any) for the Event.
- ii. It is the duty of the AO and MAA to inform the membership of the details of general and wargear authenticity for Events, and they shall maintain strict control over this aspect of the Society's function. The member shall bear in mind that, after safety, standards of authenticity are the prime and abiding interest of the whole Society.

## Authenticity Provenance

Before an item can be used within Regia it must fulfil three criteria:

### 1. It must be based on Evidence

Evidence should be provided from archaeological finds, illustrations or writings of the period, ideally all three.

### 2. It must have been intelligently Interpreted

Some finds or illustrations are obvious in their usage, a sword for instance. Others are less so. For example the Viking furry hats, as seen in numerous books, are a classic example of a bad interpretation of a find.



*Unacceptable* furry hat

### 3. It must be used in Context

The focus of Regia is to recreate people and items that are likely to have been found in Britain. Even if an item has been found and convincingly interpreted it does not mean that it can be used unless it can be argued that the character that is being portrayed could have had it. Portrayals need to be consistent, for instance a peasant would not wear a silver brooch and an English woman would not wear a hangerock. Geographical context is also important; a Varangian guardsman or a Rus trader is unlikely to be found in England, for example.

Events where “Unusual” characters could be expected will be announced well in advance – and even then only a limited number may be allowed, so check with the Authenticity Officer first. Please do not turn up and expect to portray someone away from the mainstream.

## ***Abraham dreams of the Apollo 15!***

### ***A hypothetical example of bad interpretation***

*An unchallenged interpretation of this image could lead to all kinds of interesting issues on the LHE.*

*The King James Bible translates this scene as*

*“behold a smoking furnace, and a burning lamp that passed between thoses pieces”.*



*Lord’s Covenant with Abram: Genesis 15:17*  
*(British Lib. Cotton Claudius B IV, “Hexateuch”, f.27r c.1025-1050AD)*



*Apollo 15 Command/Service module*

## Contacting the Authenticity Team

It is the intention of the Authenticity Team to make themselves accessible to the membership. When at events members may discuss any authenticity issues with any attending member of the Authenticity Team. Alternatively you can ask questions by either:

- Posting your query on the 'Regia Members' Facebook group – please clearly mark the post as 'Authenticity Query' or tag one of the Authenticity Team in your comment.
- Posting on the Regia egroup – please clearly mark the subject line as 'Authenticity Query'
- Sending an email to [authenticity@regia.org](mailto:authenticity@regia.org)

Questions will be answered as quickly as possible, but please bear in mind all the Authenticity Team are volunteers and have lives outside the sphere of Regia. Also note that it is not the job of the Authenticity Team to act as your personal researchers, particularly for obscure foreign items.

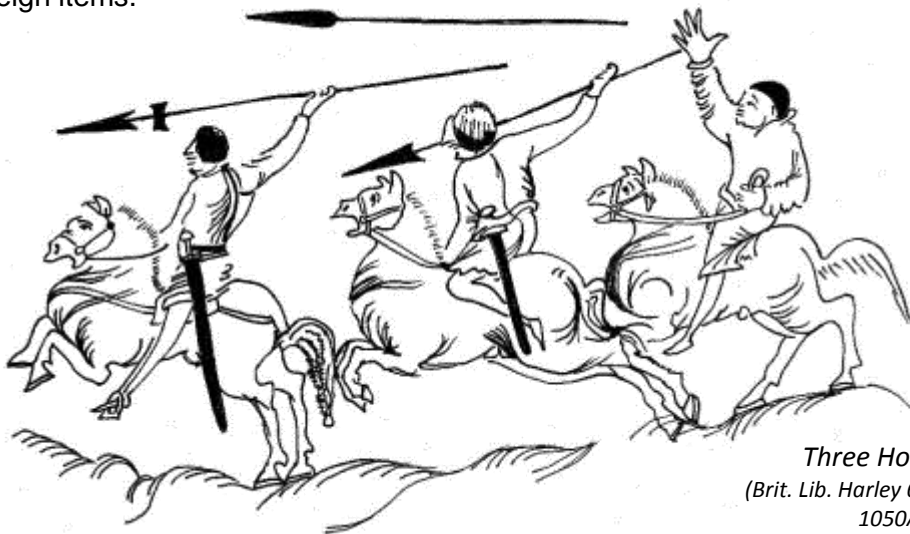

*Three Horsemen*  
(Brit. Lib. Harley 603 f.69r 1025-1050AD)

## The Roles of the Authenticity Team

- Authenticity Officer (AO)** The Authenticity Officer is elected for a three year term by the Witan. It is the responsibility of the AO to oversee and direct all matters of Authenticity within Regia and ensure policy is followed.
- Authenticity Deputies** Deputies assist in the final decision making process on authenticity policy, and act on the AO's behalf in his absence at an event. Deputies usually also have an area of expertise that they 'head up'.
- Authenticity Assistants** Assistants assist the AO in checking kit and equipment at events and help answer questions regarding the interpretation of the AO regs. They also get a say in forming authenticity policy. They can act on the AO's behalf at an event in the absence of the AO or any Deputies.
- Authenticity Specialists** Specialists assist the Authenticity Team with advice and expertise. They do not generally act directly with the membership, but are often happy to assist with information pertaining to their area of expertise.



## Authenticity Checks

It is every Regia member's personal responsibility to ensure that their own displayed kit and any kit lent by them adhere to these Authenticity Regulations. Additionally every member should actively help to ensure that all Regia members also comply with these Authenticity Regulations by advising fellow members if they are not doing so.



*Zodiac Gemini*  
(British Lib. Arundel 60 f.4r  
c.1073AD)

- At the start of each day at a Regia Event civilian members and the Wic will be visually checked by a member of the Authenticity Team and the Living History Co-ordinator or Deputy.
- Warriors will be checked at the morning battle practice and again before the afternoon battle.
- A check of the Wic will be made 20 minutes after the end of the battle practice and the afternoon battle to ensure that the warriors have got out of their fighting kit.
- Tours of the site will also be made during the day by members of the AO team.

If a member arrives on site after the morning checks, or else missed them for any other reason, then it is their responsibility to find a member of the Authenticity Team to check their kit. This also goes for opening up a tent for display to the public later in the day or starting a new craft display.

It is particularly important that warriors present themselves to a member of the Authenticity Team as early in the day as possible so as to be able to correct any unacceptable kit prior to the final pre battle check when they will have no time to do so.



*Zodiac Gemini*  
(British Lib. Arundel 60 f.4r  
c.1073AD)

If you believe that someone is wearing something that is inappropriate for the show – please tell someone – at the time! Either approach the member directly, or ask the AO or one of his team. It may be that something new is being tried – or this individual has just not been seen yet. Dealing with it on the day is so much better than two weeks later.

It is inevitable with such a broad and often subjective topic as authenticity, that differences of opinion over interpretations or rulings may well arise, even amongst the Authenticity Deputies and Assistants. The Authenticity Kit Guide tables, at the back of this document, are provided to help make a standard by which all members can follow authenticity, knowing that the rulings presented there are fixed until such time as the regulations are.

It should be noted that whilst the Authenticity Officer actively encourages debate and welcomes reviews of new evidence from both his Authenticity Team and the wider membership, it is ultimately his responsibility to apply those rulings as the elected society officer.

## Disputes

In the event that a dispute over an item occurs, it is recommended that the member's Group Leader, or another experienced group member, should be present to assist in the discussion.



*(Bayeux Tapestry c.1076AD)*

Should a dispute occur over an item that is not covered by the regulations that item must be removed from display by the member. It may be re-presented after suitable modification or upon presentation of fresh evidence to the Authenticity Team in order for a new ruling to be made. The item may not be used at any events until a positive ruling is provided.

Temporary compromises or modifications of an item may be allowed for a set time period if judged appropriate by the Authenticity Officer or a Deputy. Such time periods will vary dependant on the item in question, such as by the end of an event, three months, next season etc. When a fighter takes to the field of combat, it may be decided that they may have to drop a rank in the warrior system until the problem is solved.

If a member feels he has been unfairly treated by an Authenticity Team member he should report this to his Group Leader, who in turn should raise the matter with the Authenticity Officer. It is recommended that this be done as a matter of urgency rather than be left until several days or weeks later.

## Authenticity checks at local events

It is the responsibility of the local Group Leader to maintain Regia Anglorum's high authenticity standards at events under their control. Accordingly, if an Authenticity Team member is not available, that Group Leader should ensure that a suitably experienced and competent member of the Society carries out an Authenticity check in accordance with these regulations. Competence in this instance can be defined as knowledge of the regulations and experience.



*Coin of King Erik of Jorvik.*

# General Do's and Don'ts

## General rulings for all clothing

Clothing should be made from either wool or linen. The cloth should be either a plain tabby or twill weave and not checked or striped although cloth with the warp and weft of a different colour may be used. Printed fabrics should never be used. Colours must be from the spectrum available from natural dyestuffs known in the period.

Linen shirts and shifts should be made from either natural coloured or bleached white cloth. Other garments can be dyed. Generally available colours include madder red, weld yellow and woad blue. For green garments you need to ensure that you use a 'yellow green'. 'Blue green' should be avoided as it would have been expensive and only available to the RICH.

All visible stitching must be hand-sewn using appropriate stitches, of which the running stitch is the easiest. Overlarge "Hollywood" stitches must be avoided. Visible stitching done on a sewing machine and any other marks of modern manufacture must be completely hidden. Hidden stitches and seams may be done on a sewing machine.

Modern garments worn underneath authentic clothing must not be visible, including socks, bra straps and T-shirts. The wearing of a mix of modern and authentic clothing, including modern earrings and make-up during a Regia event is strictly forbidden and will result in the member having to leave the display until resolved. All obviously modern or dyed hairstyles must be hidden or disguised. Obvious fake hairstyles and fake facial hair must not be used.

Each garment must be made out of the same cloth. For example, the arms of a tunic or dress should be made from the same cloth as the body. Some garments can have applied trims, and these may be of contrasting colour, and this will be noted in more detailed rulings. For the purposes of repair, garments may be patched in differing material but of a similar cloth type and quality. Similarly, inserts of different cloths may be used to expand the clothes of growing children.

In general, all garments would have been treated with care. Fraying or loose seams and hems must be repaired as soon as possible and holes must be appropriately patched. Clothing that is patched and repaired, even worn is fine, neglected clothing is not. No garment will be allowed onto a Regia display if its overall condition is deemed to be substandard.

Braids are used both for belts and for decorating garments. Good types of braid for Regia's period are tablet weave and finger braids. Inkle braid is Unacceptable. Braids may be of wool, silk or linen. If wool is used care should be taken to use a fine 2 ply yarn, although 3 ply yarn is still Allowable. Chunky wool must not be used and is classed as Unacceptable.

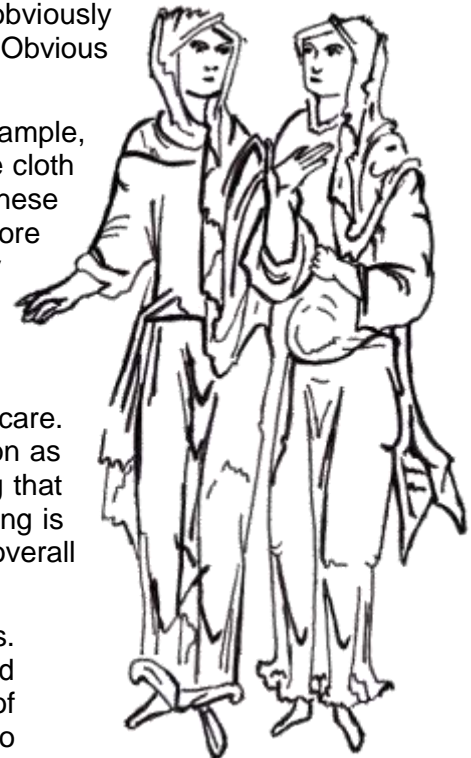

*The Virtues, Humility and Hope*

*All Periods*

*(Cambridge, Corpus Christi MS 23 fol.15v  
c.1000AD)*

## Items that are always 'Unacceptable'

The following list summarises authenticity points that members of Regia Anglorum should never do.

1. Wearing a mix of modern and period clothing in public. This also includes when walking around traders or other re-enactment societies at an event. When dressed in period kit you are representing Regia Anglorum at all times. Regia training events are exempt from this rule, but fully authentic kit is still encouraged.

Items to be aware of are: makeup, glasses, earrings, hair bungees, modern shoes, modern socks, plastic carrier bags, modern finger rings, tattoos, watches, modern dyed hair and similar things that look out of place.

2. Anything made from man-made raw materials, including but not limited to: plastic, nylon, MDF, chipboard, polyester and aluminium.
3. Anything made from raw materials not available to the character being portrayed. For example: American Red Wood, potatoes, tomatoes, African hard woods or Cotton.
4. Items that have not yet been invented. Such as: matches, modern hand tools or screws.
5. Items that come from outside of Western Europe without first getting it approved by the Authenticity Officer. Examples include: East European helmets, Hungarian sabres or Crusader equipment.
6. Unhemmed cloth, obvious machine sewn hems, big stitches and chunky wool to cover up machine stitching or to hem a garment, clothing made from different coloured panels (Except for trims and cuffs).
7. Printed fabrics or cloth with obvious coloured flecks in the weave.
8. Leather with a chrome, suede or inauthentic dyed finish. It is best to avoid black leather.
9. Silk is limited to the RICH for caps, ribbons, trimmings and maybe the occasional lady's head covering.
10. No exposed leather pouches or box pouches (except for small fist sized drawstring pouches and Birka style pouches used in context).
11. A garment must be made out of the same cloth. This means that the arms and darts should be cut from the same cloth as the body. Separate colour trims may be applied to the neck and cuffs, but not to the hem.



*Thor – How the Victorians pictured the Vikings*



## Some Sewing Terms

### Bias edge

This is where a reinforcing strip of cloth is wrapped over the raw edge of the neck hole or cuffs. It is usually of the same material and colour as the tunic or shirt. Although we use the term bias edge, the cloth used does not need to be cut on the bias (diagonal). A strip 5cm (2") wide is usually sufficient.

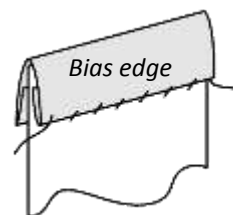

### Facing

This is where an additional reinforcing strip of cloth is sewn onto an edge of a piece of clothing around the neck hole and cuffs. The strip is usually of the same material on shirts but can be of a contrasting colour on tunics. Facings can only be up to 8cm (3") wide before 1042AD. After this wider facings may be used.

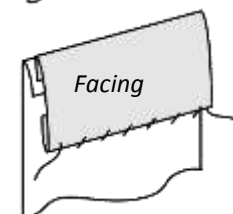

For women, only the RICH can have a facing around the hem of their dress before 1042AD (Very Early and Early periods). After 1042AD faced hems are Optional for all classes.

For men, facings around the hem of the tunic are classed as Unacceptable before 1042AD. As for women, they are considered Optional after 1042AD.

Members portraying Carolingian or Frisian women or men have the option of having a facing around their hem before 1042AD as it appears that faced hems were originally a mainland European fashion.

### Hem stitch

The two most simple hem stiches are the hem stich and running stich. Hems should always be turned in towards the body. The hem stitch is largely invisible from the outside of the garment and so modern cotton thread can be used. The running stich is more visible and so an authentic linen or fine woollen thread needs to be used.

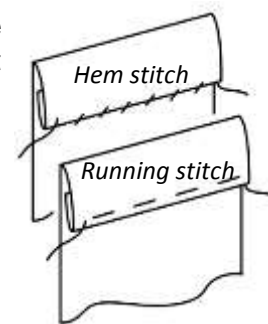

### French seam

French seams are achieved by first sewing a seam, on what will be the outside of the garment, and then turning the garment inside out and sewing another seam to cover the first.

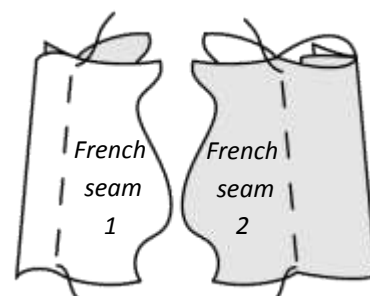

### Piled wool / Rogg

Also known as a woollen shaggy piled cloak or rug and similar to a modern flokati. A woollen cloth with tufts of unspun wool either pulled or woven through it.

### Weaves

Plain tabby and twill weaves are the most common cloth in Regia's period. Other optional weaves are broken diamond and herringbone.

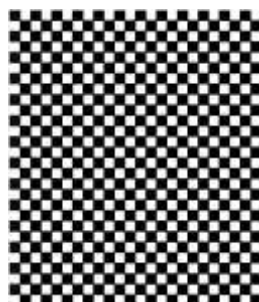

Plain tabby weave



2/2 Twill weave



Broken Diamond

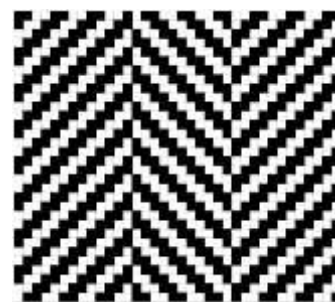

Herringbone

# Women's Clothing

## New for 2015

### New Allowed item from 1<sup>st</sup> January 2015:

**Short dresses**, for POOR women, that end mid forearm and mid shin. To wear this type of dress you must be performing a manual task and must not be wearing shoes or any jewellery. [Allowable for all Periods]

*We only have two English manuscripts depicting poor women and they both show dresses with shorter sleeves and a higher hem.*



*POOR Woman in a short dress with her lady  
All Periods  
(British Lib., Harley 603, f.65r  
c.1025-1050AD)*

### New Proposed Unacceptable item from 1<sup>st</sup> January 2016:

*This will probably be classed as Unacceptable from 1st January 2016.*

*The following item has been identified as being possibly Unacceptable. If you have any fresh evidence in support of Regia members continuing to use this item then please send it to the Authenticity Team. Remember, this can still be used this year (2015) and will only start to be phased out in 2016 if no convincing argument can be made in its favour. **It will not be fully Unacceptable until 2017***

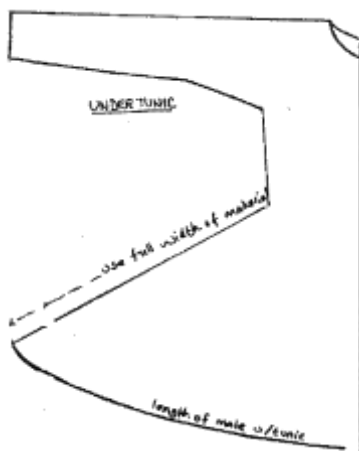

### No one-piece garments

All tunics and dresses must be made with separate arms and gores in the skirts. No tunics, dresses, shirts or shifts can be made from a single piece of folded cloth.

This supersedes the examples given in the Regia Anglorum Members Handbook 'Norman' (July 2007) pages 24 & 25.

*Although garments were made from a single piece of cloth in the Roman period by Regia's period cloth was always cut and sewn to create a relatively more tailored garment*

**Unacceptable tunic / dress construction method**  
(Regia Handbook 2007)

## Women's Garments



Woman in generic kit  
wearing a 'hood' style wimple  
All Periods

Generic kit for women consists of a dress and a head covering. An under shift, mantle and shoes may also be worn. A cloak may be substituted if a mantle is not available and for early or very late period events. Leg wear, if worn, must follow the same rulings as for men, but should not normally be seen.

### Dress

This is a T-shaped garment, flaring from underarms, bust or hips to create a full skirt of ankle length. The sleeves should be wrist length or slightly shorter, and can be quite loose on the forearm. They must not, for generic kit, be overlarge or flared. The collar line should be tight to the neck, similar to that of a man's tunic.

There is no requirement to belt the dress but if this is done, a cloth tie of ideally the same material should be used. Buckled belts should not be worn. If an ankle length under shift is worn, the skirt of the dress may be hitched up in a way similar to a man's tunic, up to about mid-calf level to expose the under shift underneath. Ultimately the hem must reach the ankle all the way round.

The neck hole may be keyhole or oval but should never be seen. If slit it should be closed by ties.

### Under Shift

This undyed linen garment is almost identical in pattern to a man's tunic. It should have tight sleeves, which may be long enough to cover the hand, but would normally be worn pushed back on the wrist. The skirt of the under shift, like the dress, should be ankle length but may be cut to a fuller pattern to the dress if the intention is to show it below the dress.

On hot days the under shift may be worn without a dress by working women on the wic.

### AO Special Mention:

#### **More plain linen shirts and shifts**

*A natural or bleached linen is encouraged for shirts and shifts. As undergarments they would have been washed more frequently and also been worn less visibly. As such, it is considered unlikely that people would have bothered dyeing them as any dye would have washed out over time.*

#### **No rolled up sleeves**

*Clothing from our period is usually shown with tight sleeves. As such they would have found it impossible to roll their sleeves up their arms. If you do this then your sleeves are too loose and you would do well to tighten them.*

“...any woman who prays or prophesies with her head unveiled disgraces her head—it is one and the same thing as having her head shaved. For if a woman will not veil herself, then she should cut off her hair; but if it is disgraceful for a woman to have her hair cut off or to be shaved, she should wear a veil.”

*St. Paul, Letter to the Corinthians*

## Head coverings

All women and girls who have passed puberty must cover the tops of their heads. A simple headscarf is sufficient for “domestic” purposes, such as working around a fire.

However, for “going out” or performing high status activities (such as embroidering or music) a more formal style of head covering must be worn over a cap or scarf. All outer coverings should partially cover the lower neck and breast bone; a good rule of thumb is that they should hide the neckline of the dress underneath and no hair should really be easily visible.

No circlets or bands should be worn over the head covering. Embroidery is for RICH English only and is only found on headbands worn under the head covering. Simple decorative stitching is allowed, but most outer coverings should be plain and ideally of natural or bleached linen or wool. It is worth noting however that pure white linen is considered RICH.

So basically a lady should wear a head covering consisting of two parts, a base layer that may be a cap, headscarf or headband. Over this should be worn the outer covering of a wimple or veil that is typically pinned in place.



*Pala*  
(B.L. MS Cott Galba A XVIII  
f.120v)

### Veil (All Periods)

A piece of cloth that is wrapped around the head and shoulders as a covering and is usually pinned to a cap or band beneath. Veils should be worn in such a way as to cover the hair and neckline.



*Veil*  
(Cam. Corp. Christi  
MS 23 f.15v)

### Palla (Very Early to Early / 800-980AD)

A large rectangle of cloth worn draped over the head and pinned at the throat with a brooch.

### Wimple (Mid to Very Late / 980-1200AD)

A simple shaped head covering that is sewn together like a small hood and covers the hair and neckline.



*Long Headband*  
(B.L. MS Stowe 944 f.6r)

### Headbands under the head covering (Mid to Very Late / 980-1200AD)

Elaborate headbands [RICH] may have some decoration and long 'tails' that hang down the front or back under the head covering. Headbands hide the hairline.



*Wimple*  
(B.L. MS Cott Cleo f.7v)



**POOR Women's Head Coverings**

English or Viking Indoor wear (These can only be worn on the Wic)



*Headscarf worn Viking style with hair visible [POOR]*

**Headscarf [POOR] – Allowable**

The drawing to the left is from Almgeren's 'The Viking', published in 1966, where he introduced the idea of Viking women wearing a simple headscarf.

Currently we have neither artistic nor archaeological evidence to support such a garment. It is allowed purely because some sort of simple head covering must have been worn by the POOR to cover their hair.



*Headscarf worn English style with hair hidden [POOR]*

**English Cap [POOR]**

A simple cloth cap often tied or perhaps pinned in place. Made slightly larger than the Viking Cap so that it can cover the hair. It can only be worn on the Wic.



*English Cap large enough to hide the hair [POOR]*



*Simple small Wimple*

**English Outdoor wear**

**Simple small Wimple (Mid to Very Late / 980-1200AD)**

Basically the same as a normal wimple but sized to cover less of the shoulders and back.

**English and Viking**

**Hoods (Allowable)**

Although we have little evidence for women wearing hoods they are allowed to provide another alternative if, for instance, a wimple or veil is unavailable. They are also useful for women who have just come off the battle field. Please note that women wearing hoods is not encouraged.



*Hood (Skjoldehamn, Norway)*

**Belts, waist ties and sashes**

Thin braided belts or no belts at all are encouraged. Cloth or woven sashes worn over a woman's mantle may be wider. They may be knotted, but the knot should not be prominent (we are not doing Geisha re-enactment!).

**AO Special Mention: *Less women with leather belts***

*Women wearing buckled leather belts are unacceptable. However it is still acceptable for women to wear tied leather belts. After 1042AD women are often depicted with no belt at all.*

## Cloaks, Palla's and Mantles

A cloak made from a simple rectangle of cloth. Before 980AD they are worn by all social classes. After this mantles seem to be preferred by women of improved status until the late C12th when cloaks come back into fashion. Cloaks must not be lined in a different coloured material.

The palla is a simple rectangle of light material draped over the head and shoulders and extended down the back to the waist. In Roman times it was often just held closed at the throat by hand. In Carolingian and early Anglo-Saxon art it is shown being closed by a disc brooch.

The mantle is an un-split garment of approximate cone shape, with a hole for the head at the point. It is worn like a poncho, and should reach mid-calf when worn loose.

When a mantle is worn, the head covering must sit over it. The front of the mantle may be belted with a wide sash made from the same cloth as the mantle in order to free the arms.



**Palla**

Before 900AD

(Stuttgart Psalter Cod. Bibl.fol.23 f.41v  
c.800-850AD)



**Cloak**

All Periods

Queen Ælfthryth

(British Lib. Cotton Vespasian A VIII  
"New Minster Charter" f.2v c.966AD)



**Mantle**

All Periods

(B.L. Cott. Cleo. F.7v)

## Necklaces and Jewellery

English women don't seem to have worn necklaces in Regia's period of interest. Jewellery is usually limited to a single disc brooch of either lead alloy or copper alloy used to fasten a cloak or the head covering. With RICH women having silver brooches for the same purpose.

## Pouches and bags

Pouches worn at the belt should be no larger than fist sized, and closed either with a drawstring, a flap or a hook of authentic design. Shoulder bags should be approximately U shaped, closed with a flap at the top and may be fastened with a leather toggle or pin.

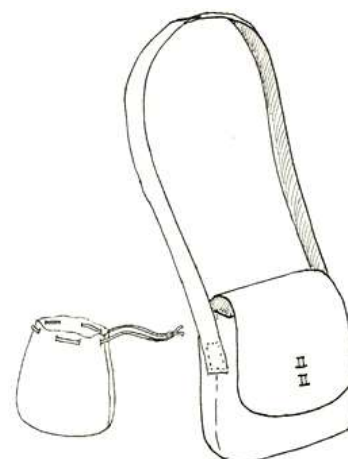

## Mittens

Although we have little evidence for gloves, people did have woollen mittens. These can be made either by nålebinding or from woven cloth.

## Shoes

These must be made of vegetable tanned leather. They must be constructed by the turn-shoe method, or a reasonable imitation of it. They should not reach up above the ankle bone for generic kit. Applied soles and heels made from suitable leather may be used to prolong the life of the shoes.



## Boots

Most of the evidence from Regia's period points to people mainly wearing slipper type shoes.

No C12<sup>th</sup> style Norman laced boots can be worn before 1041AD. Toggle style boots may however be worn pre 980AD.



*Carolingian toggled boot*  
Allowable before  
980AD

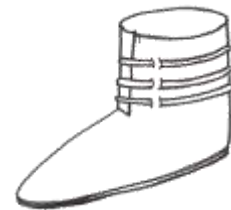

*Norman laced Boot*  
Allowable after 1041AD

### AO Special Mention: Less colourful leather

Leather should not be dyed anything other than brown. Exceptions should be for small high status items and then only red dye should be used. Leather should also not be left as pink 'Veggie Tan'. Efforts should be made to darken the leather by oiling or waxing.

## Socks

People from the period may have generally gone without socks. Woollen socks made using the Nålebinding technique can be worn and the easier to make crocheted socks are 'allowable'. Tailored sewn cloth socks are also a good option.

Alternative methods of covering the foot include foot wraps or starting the leg binding from the foot rather than the ankle. Trousers with integral feet also achieve the same result.

# Women portraying men

While on the Wic women must be dressed in female kit. This includes when performing crafts that may be considered exclusively male. The only occasions that women can dress as men, are when they are portraying either a warrior, archer or horse rider on the battlefield, or when performing as a rower on a boat.

Women who portray warriors on the battlefield have 20 minutes to change back into female kit. For more information regarding this see section 10.5 – 'Warriors returning to the Wic'.

# Viking Women

## 800-980AD (Very Early – Early)

Many reconstructions of how Vikings appeared that can be found in books or on the internet are based on out of date concepts and theories. Please be careful before you use any of these to base your kit on. Vikings from Denmark, Norway or Hiberno-Norse areas are encouraged. Members wishing to portray Viking characters from Sweden or Gotland should be willing to make the extra effort to explain to members of the public why they look so different.

- No Hangerocks may be worn without accompanying tortoise brooches (or other culturally correct paired brooches).
- No head covering needs to be worn if a full Hangerock set is worn and the member's hair is at least shoulder length and naturally coloured.
- No Viking fur brimmed hats.
- No items found only from Gotland unless representing a character from Gotland and wearing 100% accurate Gotland kit.
- A small disc brooch can be worn at the throat to close the neck of the dress or shift.
- Women wearing hangerocks may only have one string of beads between the brooches except for those portraying a RICH woman who may have two.
- A Viking Woman's coat may only be worn over a full Hangerock set. This should be closed by the use of a single disc, trefoil or equal armed brooch. No buttoned coats are allowed.
- Only Hiberno-Norse Viking women may wear a buckled leather belt (with Hiberno-Norse fittings). Other Viking women may wear a braided or tablet woven belt either at the waist or under the bust. Not wearing a belt at all is encouraged.
- Birka style pouches and hats are allowed for Vikings representing Swedish characters (not recommended). They must be at least accompanied by Swedish jewellery and preferably other eastern Viking items



*Valkyrie*  
(Silver figurine, Tuna, Sweden)



*Revninge-woman*  
(Silver figurine, Denmark)



*Oseberg Cart*  
(Wood carving, Norway c.830AD)



## Viking Women's Head Coverings

### That can be worn without a hangerock set



*Viking Cap,  
with visible hair showing  
(York / Dublin)*

#### **Viking Cap**

A simple cloth cap, often tied or perhaps pinned in place, such as the Coppergate or Dublin style caps. May be worn by Vikings on or off the Wic.

Sizes vary between 14x38cm (5½"x15") to 18x59cm (7"x23¼").

#### **Dublin Headscarf or Headband**

A simple rectangle of cloth that can either be worn as a headscarf or by folding it into thirds, as a headband. The short ends of the rectangle are usually tasselled. May be worn by Vikings on or off the Wic.

Sizes vary between 15x60cm (6"x23½") to 24x70cm (9½"x27½").



*Tasselled Viking  
headscarf,  
worn tied back  
(Dublin)*

### That must be worn with a hangerock set



*Bare hair  
(Hårby, Denmark)*

#### **Bare hair**

Viking women do not have to cover their hair provided a full Hangerock set is worn and the member's hair is at least shoulder length and naturally coloured.

#### **Sprang Hairnet (Allowable)**

Bare hair held up in a 'bun' by the use of a sprang hairnet. The same restrictions apply as for bare hair above.



*A figure possibly wearing  
a sprang hairnet  
(Klinta, Oland)*

"Each woman wears on either breast a box of iron, silver, copper or gold; the value of the box indicates the wealth of the husband. Each box has a ring from which depends a knife. The women wear neck rings of gold and silver, one for each 10,000 dirhems which her husband is worth; some women have many. Their most prized ornaments are beads of green glass of clay, which are found on their ships. They trade beads among themselves and they pay a dirhem apiece. They string them as necklaces for their women."

Ibn Fadlān describing Viking Rūs women. 921-922AD

# Norman Women

1041 – 1180AD (Late – Very Late)

Norman kit is on the whole very similar to that worn by the English and becomes more so over time. Fashions changed throughout this period and there are many variations to those listed here and in the Event Guides. If you have an item that you wish to use that is not covered by these regs then this is fine provided that you can produce the provenance for it when requested.

- No “sausage plait” style of head coverings. This is where a scarf is tied down the length of a ponytail with a criss-cross of braid.
- From 1150AD onwards open style veils may be worn. Although common in Europe before this period they only appear in England at the end of the 12<sup>th</sup> century.
- Dresses may be side laced although this is not recommended. If laced you should not be able to see the under shift.
- RICH women may wear a Norman style or bliaut sleeved dress. The earlier style of Norman dress has wide fluted sleeves starting from above the elbow and is slightly fitted in the waist. The later bliaut style of dress has two distinct types of sleeves, square and rounded, with the drape starting below the elbow.



*Woman in a common style of Norman dress (BNF Nal 1390 “Life of Saint Aubin” 1100AD)*



*Norman style Dress  
C11th*

*(New York, Pierpont Morgan MS.709 fol.1v c.1051-1064AD “Possibly Judith of Flanders”)*



*Bliaut dress – Rounded Style  
C12th*

*(St Albans Abbey, f.10r c.1150AD)*



*Bliaut dress – Square Style  
C12th*

# Angevin Women

## 1180 – 1215AD

The Angevin period is an extension of Regia's core period. To make participation for the members easier, allowances have been made for the use of Regia generic kit. The hope is that people with the correct period specific kit will be at the forefront of any Angevin period event.

- Sleeves should be tight
- Loose sleeves are rare in this period and would probably have been considered 'old fashioned' by other high status women. As loose sleeved dresses would have only been worn by those of high status, it would seem logical that not many women would have worn them.

Tight sleeves or Magyar style sleeves should be worn instead.

- Open style wimple were quite fashionable and may be worn. These are a rectangle of cloth simply draped over the head leaving the throat exposed.
- A barbette may be worn only by women portraying a very RICH character after 1200AD. Worn with an open wimple the barbette is a piece of cloth worn under the chin. These do seem to have been very cutting edge fashion at this time.
- Unlike the preceding Norman period belts are an Optional fashion accessory for women in the Angevin period. When worn they are often visible, can have buckles and can be worn with a long trailing belt strap end hanging down the skirt to about knee to mid-calf.



*Angevin period Peasant*  
(Koninklijke Bibliotheek, MS.76 F13, f.10v)



*Open Veil*  
after 1150AD  
(Hungarian Psalter  
c.1170AD)

*Barbette*  
Eleanor of Aquitaine  
after 1204AD  
(Fontevraud Abbey)

**AO Special Mention: Less Women with dresses that have Norman or bliaut style sleeves at Angevin period events**

Already only worn by the RICH and although possibly still worn they would have been classed as very old fashioned.

## Restricted Women's Clothing

There are some items that are allowed but only if certain other prerequisites are met. They are labelled [R] in the Event Kit Guides. Items can fall into this category for many reasons but the intention is to limit their number while still allowing a few examples within the society.

Be warned these items run a higher than normal risk of being banned. Failure to adhere to the exact letter and intention of these rulings will mean that you will be asked to remove the said item from display

### Head bands or circlets worn over the head covering [RICH] (Mid Period)

Occasional depictions show either gold, embroidered textile or brocaded tablet weave bands being worn over the head covering. As the depictions are rare and hard to interpret they are discouraged in Regia. Head bands of either gold, embroidered textile or brocaded tablet weave may only be worn by women portraying RICH characters and the band must be of extremely high status.



*Hexateuch  
c.1025-1050AD  
(B.L. Cotton B IV f.75r)*

### Short dresses [POOR] (All Periods)

Dresses that end at mid-forearm and mid shin, and that show bare forearms and lower legs, are only allowed to be worn by POOR women who are performing manual tasks. No shoes or jewellery are allowed to be worn with this garment.

### Leather buckled belts [V] (Very Early to Early)

A few buckled leather belts have been found in Hiberno-Norse areas of Scotland. These also have quite distinctive fittings. Women portraying Hiberno-Norse characters may wear a leather belt as long as it has the correct Hiberno-Norse style of fittings.

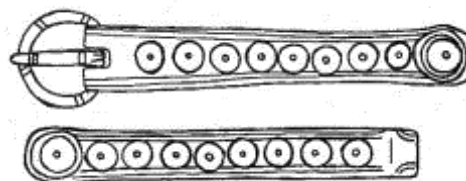

*Female Burial, Kneep, Scotland.  
10<sup>th</sup> Century  
(after Welander 1987)*

### Cloak with different coloured lining (Very Early to Very Late Periods)

Cloaks should be lined in the same or similar material. Only members representing RICH characters of Earls status or higher may wear a cloak lined in a contrasting colour. This portrayed status must be obvious to the AO Team. If not you will be asked to remove the item.

### Patterned cloth (All Periods)

Striped or checked cloth is usually not allowed but some period examples have been found. Men or women may only wear striped or checked cloth if it is of a close replica of an original find, particularly in regards to the original colours and its use. Ensure that you have the provenance information available if asked for by a member of the AO team.

### Furry shoes (Rivelins) [POOR] (All Periods)

Made from a single piece of untanned hide with the fur often left on the outside of the shoe. These may only be worn by a person portraying a POOR character. This means only wearing either a tunic or dress as your only garment, and possibly a cloak. No metal items except for possibly a small knife. All colours should be natural wools or linen.

### Black Leather (All Periods)

Black leather is authentic but is restricted to reduce the amount shown at Regia events. Black leather is only allowed if it has been tanned using a fully authentic method and to restrict its use further, only those who have been members of the society for more than five years may have a single (one) item of black leather. Gloves, leather jacks, gambesons, hoods, hose and leather fronted shields are not allowed to be tanned black.

# Men's Clothing

## New for 2015

### New Unacceptable items from 1st January 2015:

*These have completed their 12 months' notice. The intended phasing out of these items was published in the previous AO regulations. They have completed their 12 month notice period and any amendments have been included in the descriptions below.*



Long tunic

Only after 1141AD  
(St Albans Psalter p.416)

### No long tunics (man dresses) before 1042AD.

*Before 1042AD tunics that end more than 5cm (2") below the knee will not be allowed. Tunics from Regia's 'very early' to 'mid' periods come in two distinct lengths. The shorter almost universal style ranges from around 5cm (2") above the kneecap to the middle of the kneecap when rucked. The bottom of the kneecap is almost always visible. The longer robe style always comes to the ankle and is only worn by aristocrats sitting in a formal setting and never by combatants.*

### No tunic facings over 8cm (3") wide before 1042AD

*Facings on tunics do not appear in English manuscripts prior to the 980's. From this point on facings tend to be no more than 8cm (3") wide. After 1042AD some men are depicted wearing the more continental style facing that extends to the shoulder but these depictions are still rare. It is also recommended that keyhole facings should ideally end in a point on the chest as this seems again to be virtually ubiquitous in English art.*

### New Allowed item from 1st January 2015:

**Men's tunics** may now end up to 5cm (2") above the knee cap when belted and rucked. (See 3.4.1 – No long tunics before 1042AD). Although it is still recommended that the majority of tunics should reach to the knee. [Optional for all Periods]



Short Tunics  
All Periods

(British Lib. Cotton Tiberius B V,  
"Tiberius Calendar" f.3r. c.1025-1050AD)



**New Proposed Unacceptable item from 1<sup>st</sup> January 2016:**

*This will probably be classed as Unacceptable from 1st January 2016. The following item has been identified as being possibly Unacceptable. If you have any fresh evidence in support of Regia members continuing to use this item then please send it to the Authenticity Team. Remember, this can still be used this year (2015) and will only start to be phased out in 2016 if no convincing argument can be made in its favour. It will not be fully Unacceptable until 2017*

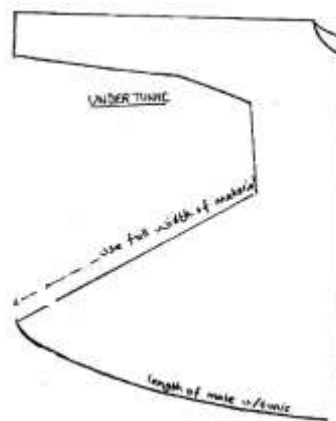

**Unacceptable tunic / dress**  
construction method  
(Regia Handbook 2007)

**No one-piece garments**

All tunics and dresses must be made with separate arms and gores in the skirts. No tunics, dresses, shirts or shifts can be made from a single piece of folded cloth.

This supersedes the examples given in the Regia Anglorum Members Handbook 'Norman' (July 2007) pages 24 & 25.

*Although garments were made from a single piece of cloth in the Roman period by Regia's period cloth was always cut and sewn to create a relatively more tailored garment*

## Men's Garments

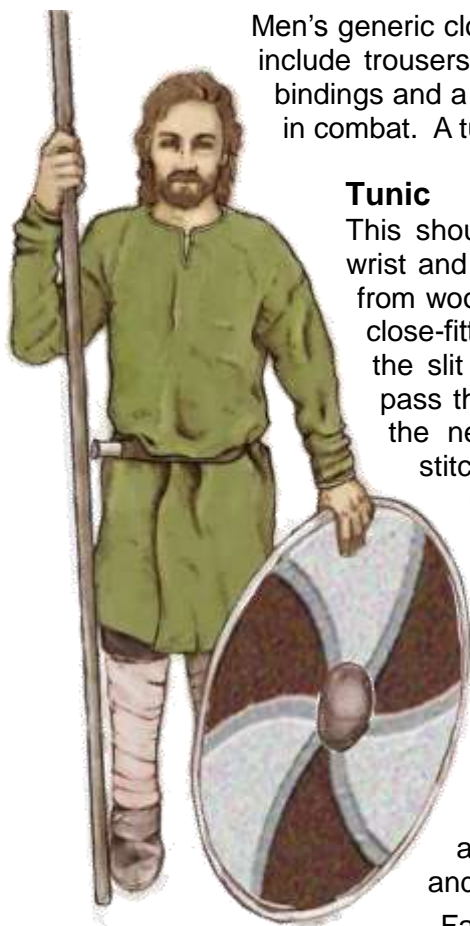

Man in generic kit with generic wargear

Men's generic clothing consists of a tunic and waist tie. Other optional items include trousers (or hose and braies), shoes, a cloak, an under shirt, leg bindings and a leather buckled belt. This does not apply to mailed warriors in combat. A tunic or shirt must be worn at all times during a display.

**Tunic**

This should generally be T-shaped, with sleeves that taper to the wrist and a body that flares out from the hips. Tunics can be made from wool (Encouraged) or linen (Optional). It should be reasonably close-fitting around the neck, and if a "keyhole" neckline is chosen, the slit should be made only large enough to allow the head to pass through; it may be closed with ties. It is recommended that the neck be edged with a bias style strip or reinforced with stitching.

The sleeves must reach at least to the wrist, and should be long enough to cover the hand, provided that they are normally worn pushed back to the wrist. Tunics should be worn rucked up over a belt or tie. When worn like this the tunic must come to at least just above the knee, although it may be worn higher under certain circumstances. Tunics substantially longer than knee length must normally be pulled through a belt to raise the hem to knee level. Triangular pieces (called "gores") are inserted into the skirt of the garment, to increase the amount of flare. These can be inserted at the side seams, and at the front and back.

Facings (sometimes called "Trims") should be avoided for generic kit.

### Under Shirt

Under Shirts are usually made from natural or bleached linen. The under shirt should be hidden, and not be seen at the cuffs or hem. In general it should follow the pattern of the tunic although they can be side split or front split (after 1041AD). The under shirt may only be worn on its own only if physical work is being performed.

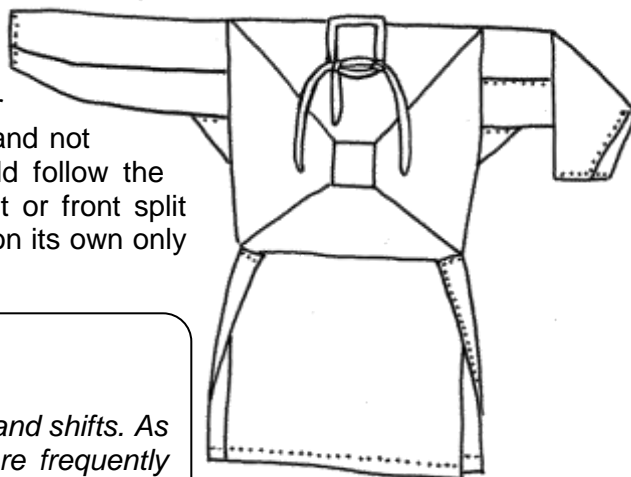

Viborg shirt C11th

#### AO Special Mention:

##### **More plain linen shirts and shifts**

*A natural or bleached linen is encouraged for shirts and shifts. As undergarments they would have been washed more frequently and also been worn less visibly. As such, it is considered unlikely that people would have bothered dyeing them as any dye would have washed out over time.*

##### **No rolled up sleeves**

*Clothing from our period is usually shown with tight sleeves. As such they would have found it impossible to roll their sleeves up their arms. If you do this then your sleeves are too loose and you would do well to tighten them.*

### Waist ties and Belts

Belts and waist ties should generally be no more than 25mm (1") wide. The ends of belts or ties may have strap ends of authentic pattern attached. Ties may be made of cloth, braided textile or alternatively from leather by using the "split end" form.

Belt buckles must be of D shape to an authentic pattern and can be made from iron, copper-alloy or bone. Belts may have leather or metal hoops or slides on them made to authentic design to retain the end around the waist. The end of the belt should not be overlong, or tied up in a knot that hangs down.



Strap end showing at waist  
(B.L. Harl. 2886 f.27v C11th)

#### AO Special Mention: **No long belts before 1180AD**

Belts before 1180AD should not hang down from the waist. The excess strap must be kept to a minimum and may be either fed through a leather or metal loop or alternatively knotted off.

### Trousers or hose and braies

Trousers can be made from wool ('Encouraged') or linen ('Optional'). Trousers should come down to at least ankle length, and can have integral feet. They must be close to the lower leg with no folds or bagginess. Loose trousers classed as 'Unacceptable' can be changed to 'Encouraged' by the use of leg bindings.

Hose are stocking like garments reaching up to at least mid-thigh, usually worn with a set of (typically) wide baggy linen shorts (called "braies") to cover the crotch. The ends of these braies should be tucked into the tops of the hose. Hose should come down to at least ankle length, and can have integral feet. They should be tight to the lower leg – making them from wool and cutting the cloth "on the cross" is recommended to achieve a leg hugging shape.

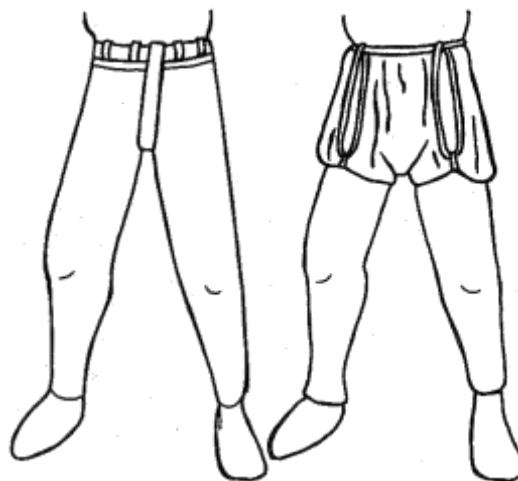

Thorsberg style  
Trousers

Hose & Braies

## Cloaks

These are rectangular garments made of wool. They may be made from one or two layers of material but all layers need to be made from the same cloth and colour. Trims may be applied on the edges. Cloaks should be held closed with a suitable pin, brooch or simple tie. For a right-handed individual, the closure should normally sit on the right shoulder.

As a general guide, cloaks should be as wide as your outstretched arms, and long enough to go from your shoulder to the knee, although shorter cloaks that reached just past the waist were also frequently seen. Most cloaks are just longer than the tunic when worn.

## Leg bindings

These are long woollen strips of cloth usually worn spirally around the lower leg from ankle to just under the knee, thus ensuring a close fit. 3m (10') or more is required per leg. Leg bindings should not be 'cross-gartered' unless worn by Normans.

### AO Special Mention: **Less loose tunic cuffs and loose trouser legs**

*Clothing of the period always seems to be worn tight at the sleeve and to the leg. Clothing should be so tight as to just allow the hand to pass the cuff or the foot to pass through the trouser leg.*

*Excessively loose trousers or cuffs are considered unacceptable and can lead to your garment being banned and you being asked to remove it.*



**More encouraged**  
Tight leg

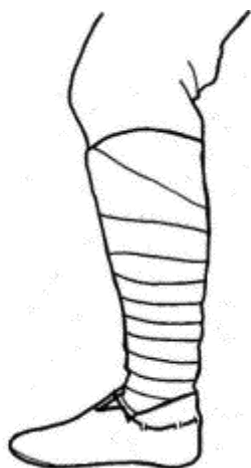

**Optional**  
Leg with leg binding

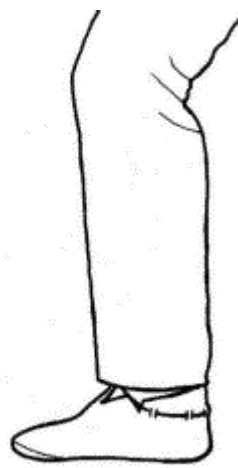

**Less acceptable**  
Loose leg

## Pouches and bags

Pouches worn at the belt should be no larger than fist sized, and closed either with a drawstring, a flap or a hook of authentic design. Shoulder bags should be approximately U shaped, closed with a flap at the top and may be fastened with a leather toggle or pin.

## Mittens

Although we have little evidence for gloves, people did have woollen mittens. These can be made either by nålebinding or from woven cloth.

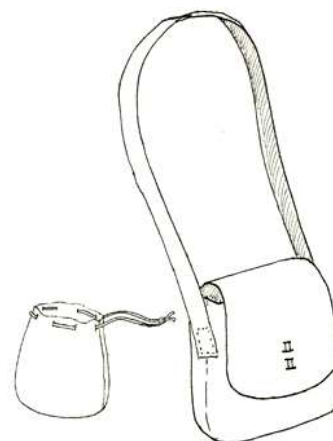

### Hats and hoods

As there is little evidence for the shape of these garments in Regia's period, they should not normally be worn as part of generic kit. However, certain simple types of head covering may be worn, especially in inclement weather or as protection from the sun or to disguise an inappropriate hairstyle. Hood patterns may be styled on those found in a later medieval context, but without any form of trailing tail (a liripipe).

Although the cloak may be arranged in such a way as to act as a hood, cloaks must not have attached hoods for generic kit.



*Hood*  
(All Periods)



*Skull cap*  
(All periods)

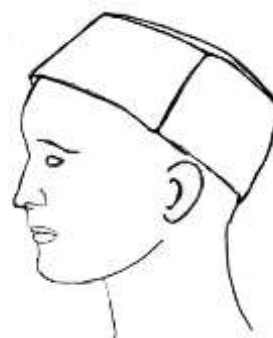

*Pillbox hat*  
793-980AD



*Conical / Pointed hat*  
793-1179AD [RICH]  
Usually worn by aristocrats in judgment



*Straw Hat*  
(All Periods) [POOR] [R]  
Only wearable by POOR men  
See Restricted Men's Clothing



*Nålebound cap*  
(All Periods) [R]  
Usually classed as Unacceptable  
See Restricted Men's Clothing

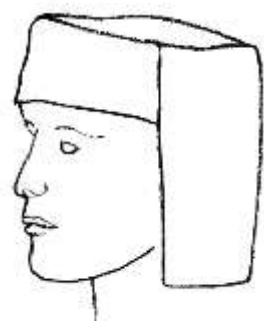

*Frisian 'Rasquet' cap*  
793-980AD [R]  
Only wearable by Frisians  
See Restricted Men's Clothing



*Frisian 'Aalsum' cap*  
793-980AD [R]  
Only wearable by Frisians  
See Restricted Men's Clothing



*Birka style hat with fittings*  
793-980AD [Viking] [R]  
Only wearable by Eastern Vikings  
See Restricted Men's Clothing

## Shoes

These must be made of vegetable tanned leather. They must be constructed by the turn-shoe method, or a reasonable imitation of it. They should not reach up above the ankle bone for generic kit. Applied soles and heels made from suitable leather may be used to prolong the life of the shoes.



## Boots

Most of the evidence from Regia's period points to people mainly wearing slipper type shoes.

No C12<sup>th</sup> style Norman laced boots can be worn before 1041AD. Toggle style boots may however be worn pre 980AD.



*Carolingian toggled boot*  
Allowable before  
980AD



*Norman laced Boot*  
Allowable after  
1041AD

### **AO Special Mention: Less colourful leather**

Leather should not be dyed anything other than brown. Exceptions should be for small high status items and then only red dye should be used. Leather should also not be left as pink 'Veggie Tan'. Efforts should be made to darken the leather by oiling or waxing

## Socks

People from the period may have generally gone without socks. Woollen socks made using the Nålebinding technique can be worn and the easier to make crocheted socks are 'allowable'. Tailored sewn cloth socks are also a good option.

Alternative methods of covering the foot include foot wraps or starting the leg binding from the foot rather than the ankle. Trousers with integral feet also achieve the same result.

## Necklaces and Jewellery

Men may only wear simple necklaces with a maximum of 2 beads and 1 pendant.

Arm and neck rings, although more commonly worn by Vikings, may also have been worn in a more limited fashion by the English up to 980AD and possibly to 1041AD. Arm Rings are always worn at the wrist, never on the upper arm.

Simple pins or ringed pins are the most common method of securing a cloak. The English also used disc brooches. Viking men never used disc brooches as they were considered a woman's item. They did however adopt the penannular in Irish and Scottish influenced areas.

We have no evidence for men wearing brooches for any other uses and they should not be used to close the tunic neck hole.

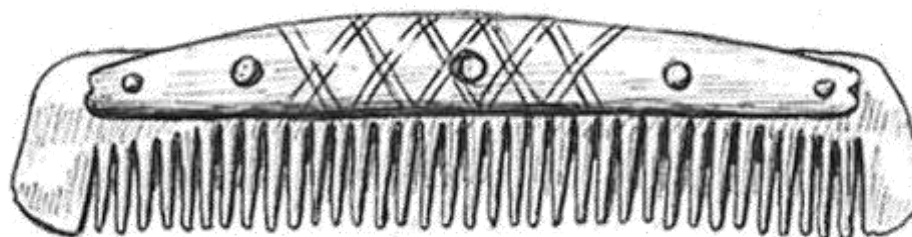

*A typical hair comb, used by both men and women*



## Viking Men

Many reconstructions of how Vikings appeared that can be found in books or on the internet are based on out of date concepts and theories. Please be careful before you use any of these to base your kit on. Vikings from Denmark, Norway or Hiberno-Norse areas are encouraged. Members wishing to portray Viking characters from Sweden or Gotland should be willing to make the extra effort to explain to members of the public why they look so different.

- No Viking fur brimmed hats.
- No items found only from Gotland unless representing a character from Gotland and wearing 100% accurate Gotland kit.
- Viking tunics are allowed to be shorter than those worn by English men but they must still reach to at least the mid-thigh when belted.
- Vikings can also wear their shirts in a different style to the English. They can either wear it tucked into their trousers or alternatively it can be worn over the trousers and secured by a belt.
- Baggy trousers must be gathered at the knee and the lower leg bound. Baggies gathered at the ankle are not allowed. Baggy trousers material must also not be stripy.
- A wide loose legged style of trouser may be worn. These usually end just above the ankle and are wide enough to cover the wearers foot.
- Viking warriors with Viking style weapons and jewellery may wear a 'Warrior Style' wraparound coat. See Viking Wargear for more information on this.
- Buttoned caftan coats may be worn but only by men representing Eastern Vikings from Sweden. All your other kit must be consistent with that of an Eastern Viking.
- Single edged swords may only be used by Viking warriors. To have a single edged sword your kit must be mainly Viking in provenance. Just calling yourself a Viking is not sufficient!
- No bead necklaces. Necklaces can only have a maximum of 2 beads and 1 pendant.
- Arm rings can be worn but only on the wrist, never on the upper arm. A Viking style neck torc can be worn but Celtic style torcs may not.
- Birka style pouches and hats are allowed for Vikings representing Swedish characters (not recommended). They must be at least accompanied by Swedish jewellery and preferably other eastern Viking items

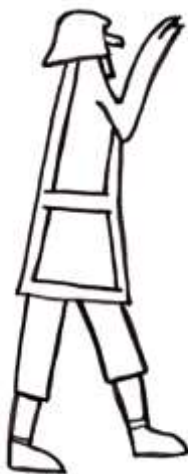

*Possible Warrior Coat*  
(Stone Carving. Grötlingbo parish,  
Gotland)



*Flared Trousers*  
(Stone Carving, Tjängvide,  
Gotland)



*Baggie Trousers*  
(Silver Figurine. Uppåkra, Lund,  
Sweden)

# Norman Men

1041 – 1180AD (Late – Very Late)

Norman kit is on the whole very similar to that worn by the English and becomes more so over time. Fashions changed throughout this period and there are many variations to those listed here and in the Event Guides. If you have an item that you wish to use that is not covered by these regs then this is fine provided that you can produce the provenance for it when requested.

- Norman men are allowed to wear their leg bindings “Cross Gartered”.
- Tunics may have neck facings wider than 3”.
- Tunics may have a skirt with a faced hem with or without embroidery.
- Tunics may have short front and back split.
- Undershirts may be split to the groin, front and bck.

## After 1080AD

- Dalmatic tunics can be worn. This is a loose sleeved tunic that ends just below the knee. They are often worn over a longer undershirt that can be seen emerging at the hem and the wrist.
- Tunics may be front and back split to the groin.



*Man in Norman dress*  
(B.L. Cott. Tib. C.vi f. c.1050AD)



*Proto-Romanesque tunic with wide neck facing and faced hem*  
(B.L. Cott. Cal. A.xiv c.1050AD)



*Long front split tunic with bliaut sleeves*  
(Dijon, Bibl. MS 2 “Moralia in Job” c.1110AD)



*Dalmatic tunic*  
(Flavius Josephus, Jewish Antiquities c.1135AD)

## Angevin Men

The Angevin period is an extension of Regia's core period. To make participation for the members easier, allowances have been made for the use of Regia generic kit and earlier styles of armour. The hope is that people with the correct period specific kit will be at the forefront of any Angevin period event

- Linen coif or straw hats are encouraged for normal or poor men on the wic.
- Leg bindings should not be worn. Tight hose (trousers are allowable) may be worn instead.

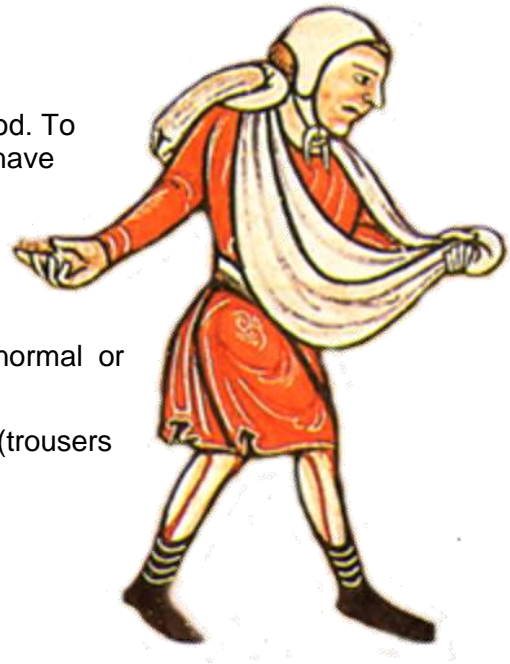

*Angevin period Peasant*

*(Koninklijke Bibliotheek, MS.76 F13, f.10v)*

## Restricted Men's Clothing



There are some items that are allowed but only if certain other prerequisites are met. They are labelled [R] in the Event Kit Guides. Items can fall into this category for many reasons but the intention is to limit their number while still allowing a few examples within the society.

Be warned these items run a higher than normal risk of being banned. Failure to adhere to the exact letter and intention of these rulings will mean that you will be asked to remove the said item from display.

### **Side split Tunic (Very Early to Mid Periods)**

These are usually only seen in European manuscripts and are discouraged in Regia. You may wear a side split tunic with a split up to half the height of the skirt if you are representing a Frisian character. The tunic must be decorated in a Carolingian or Ottonian style and you must be wearing Carolingian or Ottonian style jewellery

### **Front split Tunic (Late)**

In the 11<sup>th</sup> Century most tunics are not split. If they are front split tunics then they tend to be only small splits and decorated. Under shirts may however be split to the crotch.

*Carolingian fashion with side split tunic*

*Coronation of a Frankish Prince  
(BNF, lat. 1141 f.2, c.869AD)*

## Straw hats (Very Early – Late)

The evidence for people wearing straw sun hats between 800AD and 1100AD is elusive. Hats are depicted in both Roman times (worn by fishermen) and after 1130AD (worn by agricultural workers). Hence it appears sensible that POOR working men may have worn straw hats throughout our period.

Straw hats may only be worn by those people representing a working POOR man. This means **no trousers** and preferably no shoes. Shoes are permitted for safety reasons but they should be of either a single piece or slipper design (no shoes with toggles or boots). Tunics must be of natural coloured linen or wool and must not be decorated. Finally **you must also be working** – we don't want to see idle men standing around under fire-pit covers in straw hats. Hats should ideally be made from coarse, natural looking straw, willow, bast or other similar plant fibre and modern machine made hats should be avoided. Some examples of allowable hat shapes are illustrated below.



(Cambridge, Trinity College, R.17.1  
"Edwine Psalter" f.62r  
c.1135-1160AD)



(Cambridge, Corpus Christi,  
MS 253 f.1r  
c.1066-1200AD)



(Cambridge, Corpus Christi,  
MS 2 "Bury Bible" f.16  
c.1135AD)

## Birka style hats with fittings [V] (Very Early to Early Periods)

These may only be worn by men representing an Eastern Viking from Sweden or Gotland. This character type is not encouraged as few of them would have been seen in England. If worn it must be at least accompanied by Swedish jewellery and preferably other eastern Viking items and you must be willing to explain to the public why you look different.

## Nålebound caps (All Periods)

These are only allowed to be worn by babies and maritime sailors working on one of Regia's boats.

## Frisian caps (Very Early to Early Periods)

These may only be worn by men representing Frisians (Netherlands or Germany). An effort should be made to look continental. For example by wearing a European style tunic.

## Felt Animal masks [V] (Very Early to Early Periods)

Found in Hedeby and probably worn with a hood. These can only be worn by a Viking warrior involved in a religious ceremony. Possibly they were worn with a wraparound coat.



Felt Mask  
Hedeby c.900-1066AD



## **Bead necklace with more than 2 beads [V] (Very Early to Early)**

Necklaces can normally only have a maximum of 2 beads and 1 pendant. The only exception to this is men from Iceland who can wear full bead necklace. To do so all kit must be consistent and be provenancable to a character from Iceland. No guest items are allowed



*Beggar in hooded Mantle*  
c.1000-1025AD  
(B.L. Harley 603 f.57v)

## **Hooded Mantle [POOR] (All Periods)**

Only worn by POOR characters, especially beggars. May be worn either on its own or with braies or trousers. Men wearing this must not be seen sitting around on a wic. Instead they should be seen 'out and about'.

## **Cloak with different coloured lining (Very Early to Very Late Periods)**

Cloaks should be lined in the same or similar material. Only members representing RICH characters of Earls status or higher may wear a cloak lined in a contrasting colour. This portrayed status must be obvious to the AO Team. If not you will be asked to remove the item.

## **Patterned cloth (All Periods)**

Striped or checked cloth is usually not allowed but some period examples have been found. Men or women may only wear striped or checked cloth if it is of a close replica of an original find, particularly in regards to the original colours and its use. Ensure that you have the provenance information available if asked for by a member of the AO team.

## **Birka style pouches [V] (Very Early to Early Periods)**

These may only be worn by men representing an Eastern Viking from Sweden or Gotland. This character type is not encouraged as few of them would have been seen in England. If worn it must be at least accompanied by Swedish jewellery and preferably other eastern Viking items and you must be willing to explain to the public why you look different.



*Birka style pouch*

## **Furry shoes (Rivelins) [POOR] (All Periods)**

Made from a single piece of untanned hide with the fur often left on the outside of the shoe. These may only be worn by a person portraying a POOR character. This means only wearing either a tunic or dress as your only garment, and possibly a cloak. No metal items except for possibly a small knife. All colours should be natural wools or linen.

## **Black Leather (All Periods)**

Black leather is authentic but is restricted to reduce the amount shown at Regia events. Black leather is only allowed if it has been tanned using a fully authentic method and to restrict its use further, only those who have been members of the society for more than five years may have a single (one) item of black leather. Gloves, leather jacks, gambesons, hoods, hose and leather fronted shields are not allowed to be tanned black.

# Children



*Woman and child  
(Bayeux Tapestry c.1076AD)*

In manuscripts babies are usually shown as swaddled and then once children they are shown as miniature adults.

Children's clothes are allowed a few special dispensations. For instance unlike adult men's tunics, boys tunics are allowed to be extended by the use of a band in a different colour cloth both at the wrist and at the hem.

Girls below the age of 12 don't have to cover their hair.

## Babies

Caps are a good option for covering a baby's or a young child's head. Another allowable option is the use of nålebound hats (although they are banned for older children and adults).

Modern nappies, vests, tights, etc are allowed to be worn under authentic clothing but please make an effort to both hide them and to ensure that they are in natural wool shades or white.

It is appreciated that babies and young children cannot understand the limits placed on them by authenticity and will happily walk out of a tent with their favourite modern toy. All Regia can ask is that as a parent you make every reasonable effort to try and minimise such incidents.

# Pets and livestock

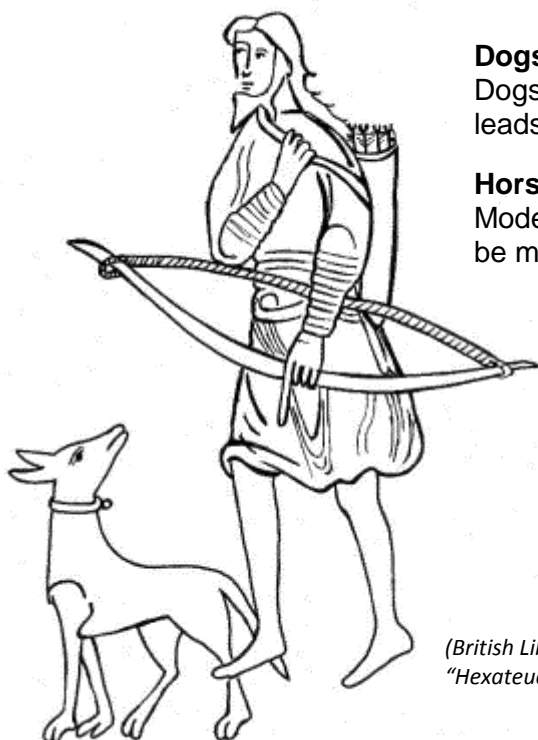

*(British Lib. Cotton Claudius B IV  
"Hexateuch" f.41v c.1025-1050AD)*

## Dogs

Dogs do not have to be of an authentic breed. Modern leads with lanyard clasps are not allowed.

## Horses

Modern saddles and tack are allowed but an effort should be made to not draw attention to them.

## Other Livestock

Other animals displayed at events must be of a type that existed in Regia's period in Britain. Although the animal does not need to be of an exact period breed.

# Warriors

## The Warrior System

To advance through the warrior system combatants must gain and improve their kit. At each level of advancement the member is expected to have:

### Level 1 – Levy – 1 Hit

A tunic, belted and rucked to knee level. This can be owned by the member or loaned.

### Level 2 - Militia – 2 Hits

A tunic, belted and rucked to knee level. Trousers or Hose – tight to the leg or with leg bindings. Shoes. At least one authentic name/character. Kit must be owned by the member.

### Level 3 - Warrior – 3 Hits

Soft kit as per the Militia, but with some ethnic, character or period specific items of kit for certain shows. Generic kit must be retained for shows where that is not appropriate. No item of kit out period. and exhibit

classd as unacceptable during its phase  
All kit to be made of good quality materials  
good quality workmanship.



*Goliath. Possibly dressed in Danish fashion.*

*(British Lib. Tiberius C VI f.9r c.1050AD)*



*(BNF NAL 1390, "Life of St. Aubin" f.7 c.1100AD)*

## Becoming a Warrior

Members seeking to advance to Warrior level must ask either two AO Deputies or an AO Deputy and an AO Assistant, who at the same time will examine their kit. Opportunities for this will normally be after the battle practice and after the afternoon battle. Advice will be given and if both deputies agree then the members book will be stamped.

## Warriors and Authenticity Checks

Just like warriors only have two hits when they remove their armour, they also forfeit their third hit if they take the field wearing any item of kit that is currently being phased out and is therefore classed as unacceptable. Hopefully this will be pointed out during the day at one of the authenticity checks and the member given time to either remove the item or modify it, but the Event Kit Guides usually make this clear and can be consulted before attending an event.

*For more information regarding the Warrior System refer to 'The Warrior System', Spring 2005, document from the Regia website.*

Eastern Viking  
War Knife  
650 - 979AD  
(Very Early - Early)

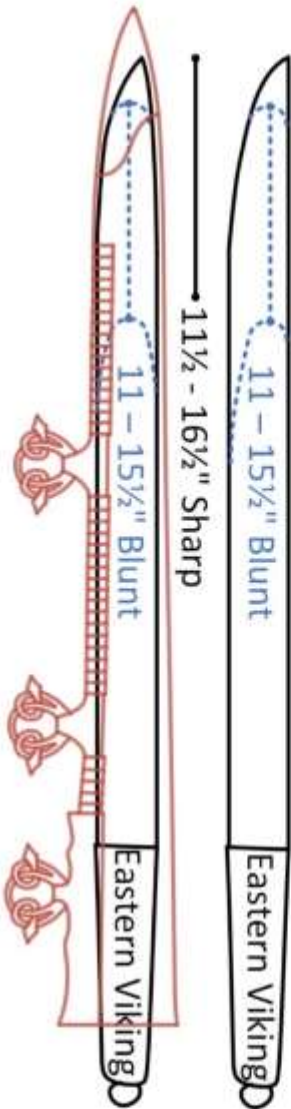

Hadseax English  
650 - 899AD  
(Very Early)

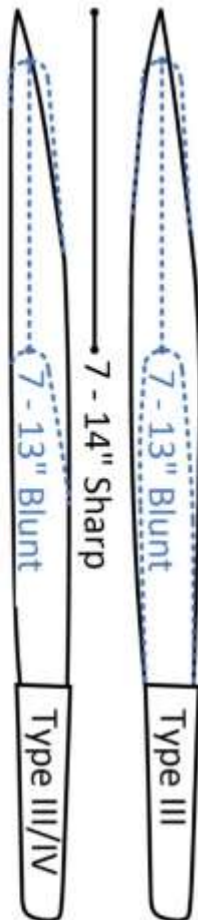

Hadseax English  
850 - 1079AD  
(Very Early - Late)

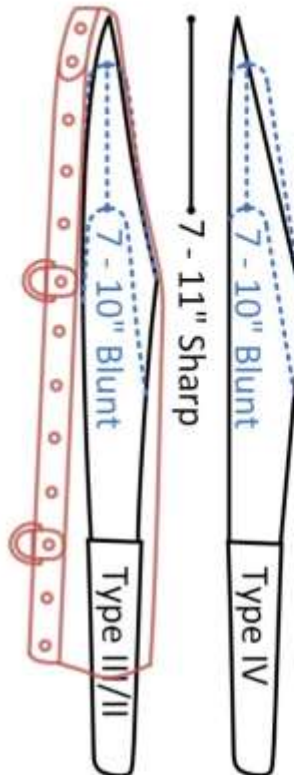

Langseax English  
850 - 1079AD  
(Very Early - Late)

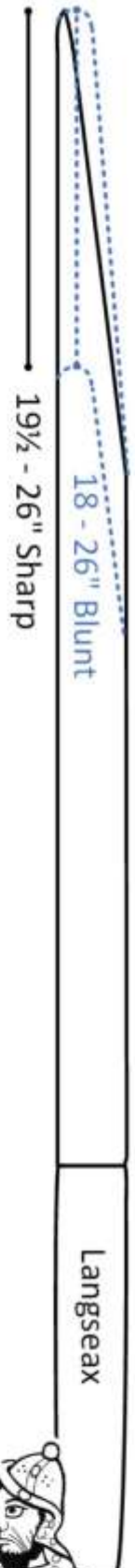

St Andrew Sarcophagus (775-800AD)



Middleton Warrior (c10th)



Stuttgart Psalter (800-850AD)



## New for the 2015 season

### New Unacceptable item from 1st January 2015

*These have completed their 12 months' notice. The intended phasing out of these items was published in the previous AO regulations. They have completed their 12 month notice period and any amendments have been included in the descriptions below.*

#### No mail on gloves

Mailed gauntlets do not appear until the C12<sup>th</sup>. These items are wrong on two counts. First we have no clear evidence of gloves and hence must strive to keep them simple in design. Secondly they are often worn by Regia members portraying poor characters who could never have afforded such an item, even if they had existed, as mail was expensive.



*Unacceptable mailed glove*



*Short Mail shirt: Early 800-980AD  
(Leiden 1 "Maccabees" PER F17 c.900-950AD)*

### New Allowed item from 1st January 2015:

**Mail shirts** that come to just below the belt but do not necessarily cover the groin for events before 980AD. [Optional for Early, Very Early]

*Early period mail shirts appear to be shorter often only just reaching past the waist.*

### New Proposed Unacceptable items from 1<sup>st</sup> January 2016:

*These will probably be classed as Unacceptable from 1st January 2016. The following items have been identified as being possibly Unacceptable. If you have any fresh evidence in support of Regia members continuing to use this item then please send it to the Authenticity Team. Remember, these can still be used this year (2015) and will only start to be phased out in 2016 if no convincing argument can be made in their favour. **They will not be fully Unacceptable until 2017***

#### No Hadseax blades over 10" after 900AD

For events after 900AD blunt combat hadseax (Scramasax) blade lengths must now be between 18cm and 25cm (7-10"). This replaces the original ruling as stated in the Master-at-Arms Regulations version 3.0 (2005) stating 7-14".

*The evidence from Regia's core period is that sharp blade lengths vary from between 7-11". Blunting the point for combat reduces the length by 1".*

Longer blades of up to 14" (sharp) or 13" (blunt) of the appropriate blade form are allowed for events before 900AD.

See page opposite for Seax types and allowable sizes.

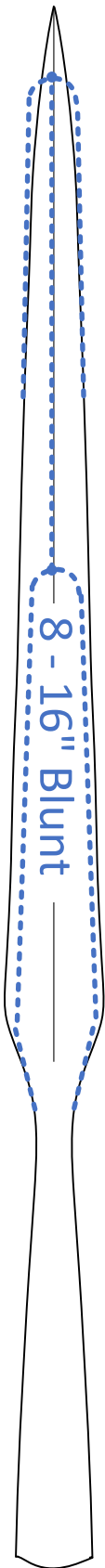

2-handed spear head with blade length between 8 - 16"

**2-handed spear-head blades must be over 8" on spears longer than 7'**  
For the first time a minimum blade length is being introduced for two-handed spear heads. Two-handed spear heads must now have a minimum blade length of 20cm (8") if used on a spear over 213cm (7') long.

*The intention is to make the use of javelin sized heads unacceptable on spears over 7' in length. This will result in the use of javelin heads on our single-handed spears and larger standard spear heads on our two-handed spears, in Regia combat.*

## Wargear

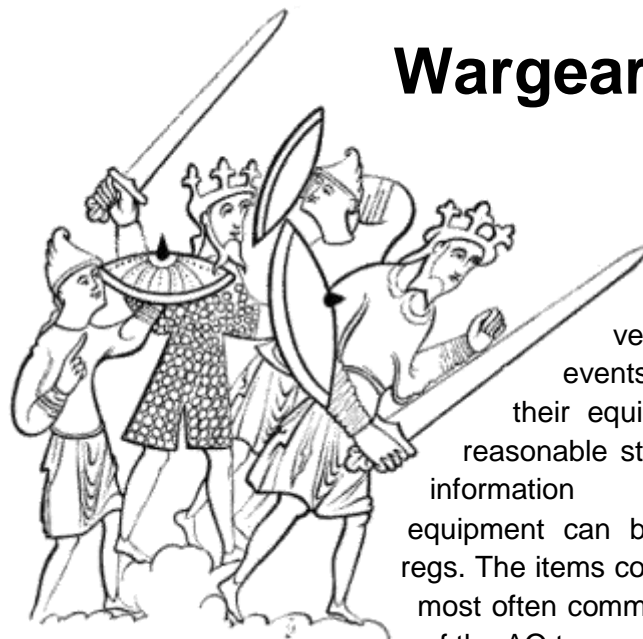

(B.L. Cott. Clau. B.iv f.24 1000-1050AD)

As combatants are a very visible part of our events it is essential that their equipment be of at least reasonable standard. More detailed information regarding military equipment can be found in the MAA regs. The items covered below are those most often commented on by members of the AO team.

### Mail shirts

The most authentic mail shirts in Regia's period are made from 6-8mm (internal diameter) alternating riveted and welded rings. For events after 900AD mail shirts must be long enough to cover the wearer's crotch. Sleeves at all periods must be long enough to reach the wearer's elbow when the arm is held straight out and armpits must be fully infilled. Mail shirts that are constructed from galvanised or zinc coated steel rings should have the zinc layer removed.

#### AO Special Mention: Less Mail shirts before 900AD

It is likely that mail shirts were not so common in Regia's Very Early and Early periods. Leaders and their bodyguards would have likely worn armour, as would have some of the RICH. To put things into perspective it is likely, based on late Roman documents, that a mail shirt was worth 20 times more than a sword during this period.

Mail shirts before 900AD may be shorter coming to just below the waist.

## Gambesons only ever worn under chain mail

These may be made from cloth or leather and may be padded or not. Any design is acceptable as long as it is not seen protruding from under the mail shirt. Gambesons may however be sewn to the mail shirt being attached by a leather strip around the mail shirts edge. Unlike on visible jacks metal buckles may be used but they must never be shown to the public. Only gambesons that match the criteria for those worn as visible armour are allowed to be displayed in armouries or as items for 'dressing the knight'.

## Gambesons or jacks worn as visible armour

Padded cloth gambesons can be worn for a limited time only on the understanding that the member is in the process of procuring a mail shirt within 12 months. Leather jacks, padded or not may be worn as visible body armour. They may be made in the style of either a waistcoat or as a short sleeved, skirted tunic. Metal buckles and fittings must not be used, Leather toggles or ties may be used to close the garment instead. Only authentic styles of leather may be used for leather jacks, no chrome or suede. Either diamond or tubed padding styles are permissible.



*Simple sleeveless leather Jack*



*Tunic style  
with diamond quilting*



*Tunic style  
with tubed quilting*

## AO Special Mention: No 'figure of eight' style buckles and pop rivets



**Unacceptable** 'Figure of eight' buckle

Buckles should be 'D' shaped. Many purchased helmets and shields come with 'figure of eight' style buckles which were only used from the C14<sup>th</sup> onwards. These can easily be modified to appear authentic by simply hack-sawing off the back half of the 'figure of eight'.

*Manufacturers also often use pop-rivets on leatherwork. These were invented only in the 1930's and must always be removed. The recommended alternative is to use a riveted buckle plate of iron or brass but folded and sewn leather is acceptable*

## Leather Scabbards

All knives and swords taken onto the battlefield must be scabbarded. Sword scabbards may be decorated with raised moulding but they may not be painted (although existing painted scabbards are currently allowable). Very simple tooling is also acceptable.



## Axes

Leather covers should be placed over the axe head when worn around the wic. Metal O-ring axe loops are not allowed on belts. Cloth or leather axe holders may be used instead, or alternatively the axe handle can be put through the belt.

## Leather Gloves

Leather gloves must not extend more than 5cm (2") up the arm from the wrist and must be in natural shades of brown or grey. No modern piping or elastic should be visible. They should not be made of suede and must be in natural shades of brown or grey. Do not use green, red or black welding gloves.

For photo-shoots please remove and hide your gloves if possible and do not display them on the Wic or on the armoury.

### AO Special Mention:

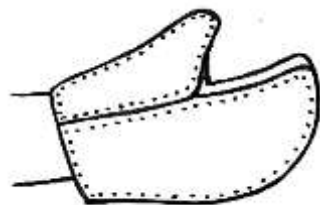

*leather covered glove*

### Less over engineered leather combat gloves

We have no pictorial or archaeological evidence for leather gloves from our period. This said it is generally accepted that protective gloves may have been worn. As always, where evidence is lacking, Regia always insists on encouraging the simplest and least obvious of designs.

Gloves should be of a simple construction and those consisting of complicated overlapping leather panels should be avoided.



*Less over engineered combat gloves*

### Less integral mailed mittens before 1180AD

Although the use of integral mailed mittens is allowable after 1080AD they did not really become popular until Regia's Angevin period, after 1180AD.

### No separate mail covered gloves

Gloves with attached mail are considered unacceptable for all periods from 1<sup>st</sup> January 2015.

## Forearm and leg protection

Leather arm or leg protection, for example greaves or vambraces, should not be seen but may be worn under tunics and trousers.

## Shields

All shields must have a boss with the exception of Kite shields used in events after 1180AD where the use of a boss is optional. Round shields may be flat or lenticular but must not be curved only in one plane. Kite shields must be curved and must not be flat. Shields should either be painted in a single colour or alternatively in a simple pattern (see chapter 10.5). If you choose a more complicated design then it is up to you to provenance it for use at the event's dateline.

## AO Special Mention:

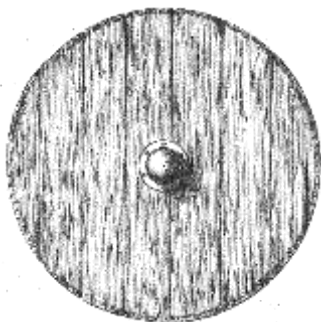

*Gokstad Shield  
94cm (37") diameter  
with holes around the  
rim 3.5cm apart*

### More large sized shields

The meagre archaeological evidence would imply that shields were usually quite large in Regia's core period with shields of 80-100cm (32-39") being common. To this end I would encourage any new shields to reach at least 5cm (2") past the users elbow when gripped. This will hopefully encourage more 79cm to 89cm (31" - 35") shields.

### More shields with sewn on shield rims

Although we cannot categorically say that shield rims were not nailed on it is more likely that they were sewn on with stitches about 3-4cm apart. The thread used can be leather thong, string (or linen thread), or sinew.

### More freshly painted shields

Shields of the time would not have been covered in ball bearing marks. They would have been new and then hacked to pieces. To this end all active combat shields should be repainted at least once a year to remove combat marks.

### Less blue paint

In Regia's period the only viable way of achieving quantities of blue paint was by using woad. Even so the process of refining it to make the paint would have been expensive. Where blue paint is used for shield designs it is recommended that it be applied in moderation and that shades should be no darker or bluer than that of 'Pebble Drift 1' from Dulux.

## Shield Designs

A selection of basic shield designs which can be provenanced by manuscript pictures or archaeological finds are illustrated below as a guide for members to base their own shield designs on.

Shields may be painted in up to four colours using these patterns, although one or two colours seem to be the most common. Remember all black shields are reserved for under 18's on the battlefield.

Authentic period paint colours include red, orange, yellow, brown, black, white and grey. More rarely grey-blues, pale greens and other colours were also used, it is best to avoid rich blues or greens as these are rare or very rich colours.

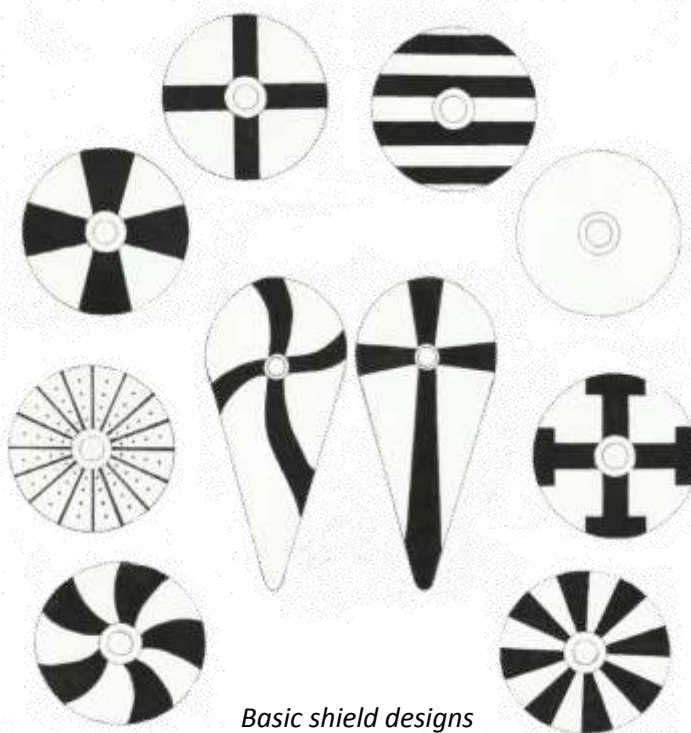

*Basic shield designs  
All Periods*



*AO Special Mention:*

**More use of single-handed spear and shield**

Every warrior should ideally take the field of battle with a shield and a single-handed spear as their starting weapon.

I would encourage all new combatants in Regia to start with the single-handed spear as their first weapon.

*More combat with single-handed spears*

*(BL. MS Add. 24199 fol.17r)*

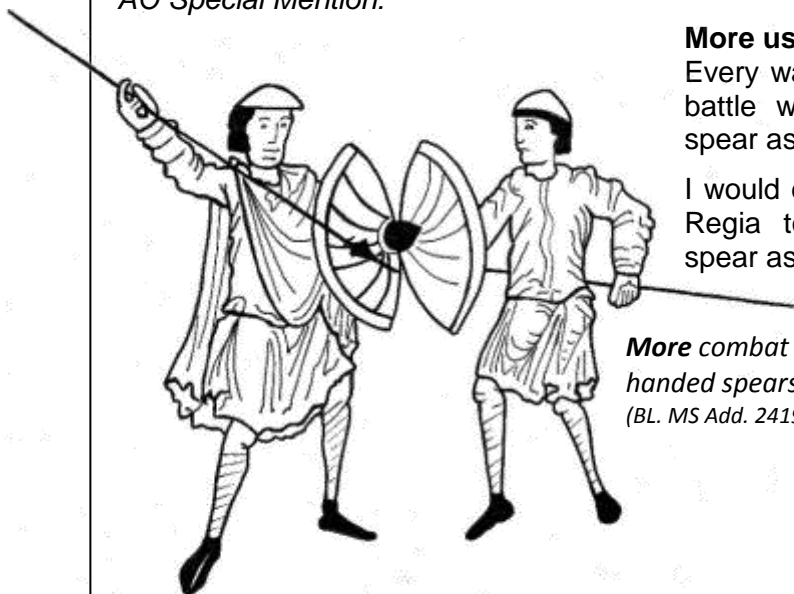

**Less two-handed spears being used by POOR warriors**

Ideally it would be nice to see only high status warriors using two-handed spears as their large spearheads would have been expensive weapons (see the new rule regarding two-handed spear head minimum length of 20cm (8")).

The use of two-handed spear and shield in combat is only depicted 3 times in Regia's period of interest (see below) and is always shown being used against non-infantry.



*A high status mailed warrior with a possible two-handed spear*

*(B.L. Harley MS.603) 1050AD)*

**The evidence for two-handed spears and shield**

Since its inception, Regia has been synonymous with the use of the two-handed spear and shield. Were we to be starting as a new society today I think things would be different.

To start with let's look at the evidence. To the best of my knowledge we have no written sources that describe this form of warfare. This is not surprising, however, as most of the writings that we have are either short, factual chronicles or allegorical poems. From archaeology we have hundreds of large spearheads. On the whole these still have thin sockets, usually less than 25mm (1") in diameter, and so would be unsuitable for the stout spear shafts that you would expect to see associated with a two-handed weapon. Another argument against their use in this manner are the manuscript images clearly showing these large spear heads being used single-handed.

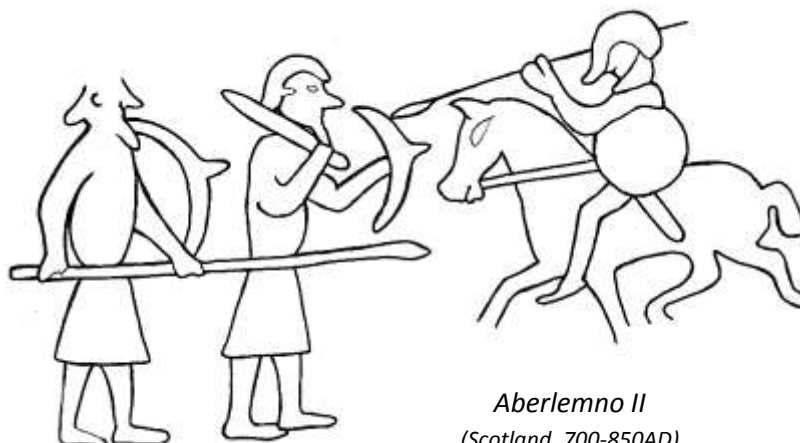

*Aberlemno II  
(Scotland, 700-850AD)*

We do however have numerous images of warriors using spears two-handed. Just not in association with a shield. This is what you'd expect as anyone armed with just a spear would automatically use it with both hands.



This leaves us with the 3 images shown on these pages. The earliest is from a Pictish picture stone depicting a battle and dating to somewhere between 700AD to 850AD. The second is from a European manuscript made in Switzerland dating to 1125-1150AD. The third is from a stained glass window in Canterbury Cathedral and dating to 1190AD.

All of these images depict warriors fighting against non-infantry.

Byzantine and Carolingian armies were known to use two-handed spears, or pikes, for use against mounted warriors. But for England we have scarce evidence for the use of mounted warriors prior to the Norman Conquest. If two-handed spears were in common use in 1066AD we would expect to see them depicted in the Bayeux Tapestry and being used against the Norman cavalry. Instead we see Dane-axe wielding warriors fulfilling this role. It appears that England and Scandinavia chose a different way to deal with cavalry than adopting the two-handed spear.

It seems then that the main use for stout two-handed spears in England was probably for use in hunting, the pursuit of the rich. This is not to say that they could not have been used on the battlefield as they would have made very effective weapons.

*"Life of St Alphege"  
window in Canterbury  
Cathedral c.1190AD*

In summary two-handed spears will **never** be banned in Regia as we have more than sufficient evidence for their use. However I would like to see them becoming a specialist weapon with only a few in use by warriors in RICH attire.

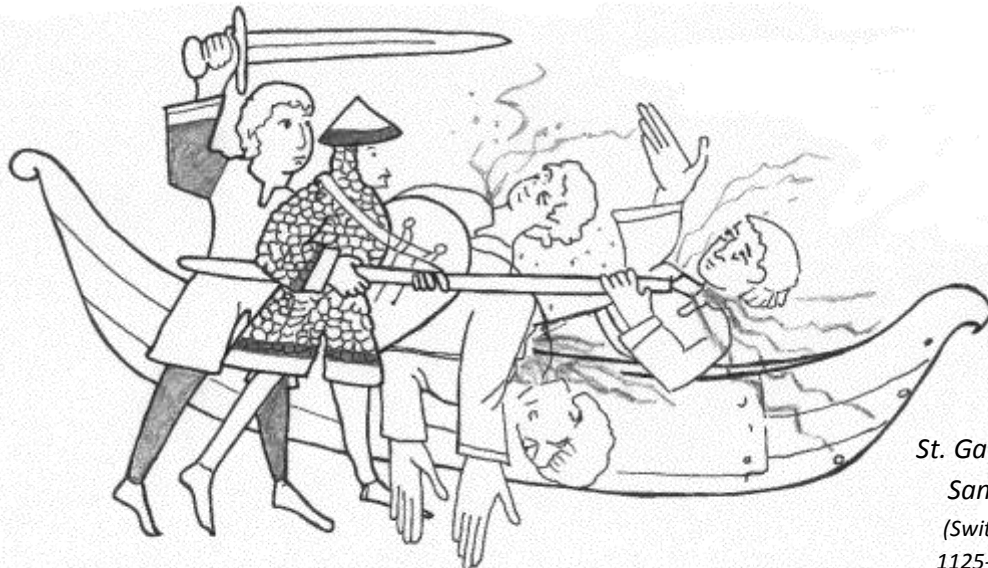

*St. Gallen, Cod.  
Sang. 863  
(Switzerland,  
1125-1150AD)*

## Viking Wargear

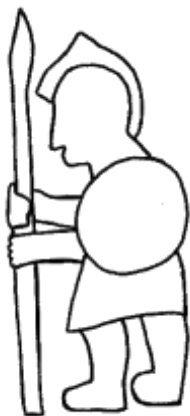

*Sockburn Warrior  
C10th*

- Viking warriors with Viking style weapons and jewellery may wear a 'Warrior Style' wrap around jacket. These must be made of wool and lined. Ideally it should have a faced or tablet woven edge. They should fold over and be pinned on the wearer's right hip.

These are warrior coats and the rest of your kit must show that you are a high status warrior. You must also not wear a warrior coat while performing manual labour. If your kit is not to an acceptable level AO will ask you to remove the coat

- Single edged swords may only be used by Viking warriors. To have a single edged sword your kit must be mainly Viking in provenance. Just calling yourself a Viking is not sufficient!

## Norman Wargear

- Kite shields must be bossed if used prior to 1180AD. After this bosses are optional. Although some bossless kite shields are depicted prior to this date, the AO and MAA decided that all kite shields must have a boss. This was necessary as no workable or fair solution could be found to limit the number of bossless kite shields in the society
- Mailshirts may be long sleeved but without integral mitts.
- Mail chausses may be worn by RICH warriors.

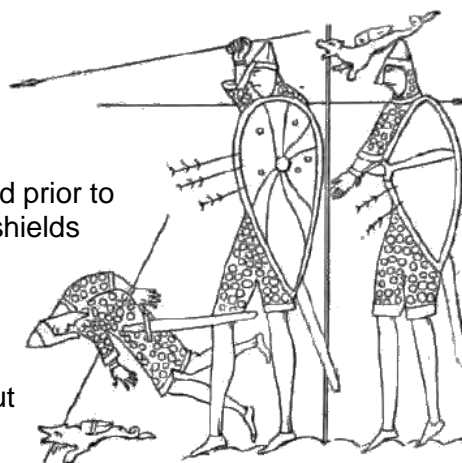

*(Bayeux Tapestry c.1076AD)*

## Angevin Knights

Those portraying knights will be expected to have a full complement of late 12th century or early 13th century kit, including a sword and soft kit. Mixing and matching earlier period items will not be acceptable for a knight. Mail coifs may be acceptable if concealed by a surcoat and other conical helm patterns are also acceptable.

- Knights may wear a full faced Helm, This must only be worn when accompanied by a full sleeved hooded mail shirt (or coif & surcoat), kite shield & the correct period sword.
- Knights may wear an optional surcoat. Ideally they should be of one plain colour and must not have a design that matches the shield. Note that 'quartered' designs should not be used and 'half' designs are rare although both are considered Acceptable.
- Scabbards may be decorated in an appropriate style and may be tanned black. Scabbards from this period often have a seam running down the body side of the blade.

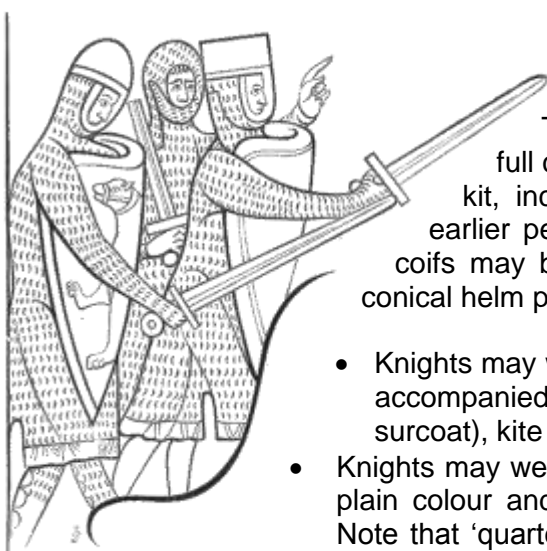

*Martyrdom of  
Thomas á Becket  
(B.L. Harl. 5102 f.32 1200-  
1225AD)*



*The Virtue 'Faith' from the Psychomachia  
fighting in her under shift  
(B.L. Cott. Titus D XVI, f.5v c. 1120AD)*

## Women portraying male combatants

Women who portray male combatants on the battlefield should make a reasonable attempt to try to look as masculine as possible when fighting in male kit.

- If you are wearing a pony tail ensure that it is tied at the neck, not at the back of the head.
- No false beards or wigs.
- No bare legs.
- No high pitched shrieking.

## Combatants returning to the Wic

When returning to the Wic after a display, combatants must get back into a civilian context within 20 minutes. This means that combatants who want to remain in their wargear on the Wic must be part of a display that would need a warrior with weapons. It is not acceptable for them to just lounge around in wargear on the Wic.

Women who portray male combatants always need to get changed back into female kit (with the exception of women portraying knights – see below). Men will have to get changed into an appropriate level of dress for the craft that they are demonstrating.

A simple method of converting male combatant kit to female kit is to remove the belt, put on a linen skirt under your tunic and a simple wimple. This simple change should only take a couple of minutes and is recommended for women who fight frequently during the day.

### Very Late and Angevin periods

Both men and women who portray knights in full armour (long sleeves and optional chausses) are exempt from the above LHE ruling due to the exceptional amount of time it takes to change and to get comfortably into full battle rig. Doing this in a rush may result in injury or other inconvenience.



*Abraham approaching Egypt  
(Oxford Bod. Junius 11 p.88 1000-1050AD)*



## Restricted War Gear

There are some items that are allowed but only if certain other prerequisites are met. They are labelled [R] in the Event Kit Guides. Items can fall into this category for many reasons but the intention is to limit their number while still allowing a few examples within the society.

Be warned these items run a higher than normal risk of being banned. Failure to adhere to the exact letter and intention of these rulings will mean that you will be asked to remove the said item from display.

### Great Polish Helm [V] (Mid & Late)

This style of helmet is eastern (Russian) in origin and unlikely to have been found in England. Only warriors portraying Swedish Vikings can use one. You must also be wearing at least 2 other items of eastern Viking provenance.

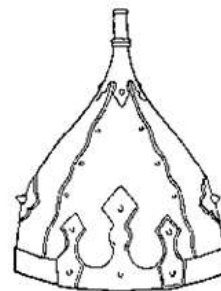

*Great Polish Helm*

### Shields painted in 4 or more colours (All Periods)

Most shields seem to be painted in only one or two colours. The use of 3 painted colours is acceptable but only warriors with 3 hits and of aristocratic appearance can use 4 or more colours. Even so the use of more than 3 colours is not encouraged.

### Shields painted in artistic styles (All Periods)

Any design that is not a simple geometric one must follow a recognisable period art style. Only full warriors with 3 hits may use an artistic shield design. As large obvious items shields painted in an artistic style can only be used at events where the art style is in period.

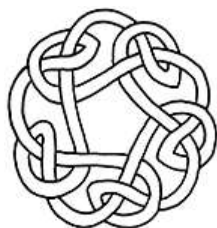

*Unacceptable Celtic Knotwork*

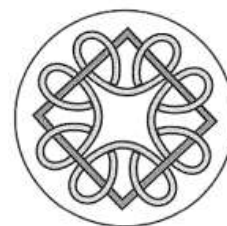

*Allowable Viking Borre Knotwork  
Early 800-980AD*

### Shields painted with heraldry [RICH][K] (Angevin Period)

This period is the start of simple Heraldic designs. Only warriors portraying RICH Knights may have a simple period correct heraldic design on their shield.

### Bows with horn nocks (All Periods)

These are only allowable if the bow is 'side nocked' and of an authentic wood. It must not be your only bow at the event and you must be willing to explain the technology behind why horn may have been used to the public.

### Mace (Late Period)

Maces may only be carried by Line Commanders on the battlefield as a badge of office. This must be agreed with the Military Officer at the event. After this period maces are used as just a weapon by [RICH] warriors

### Cloth gambesons worn as armour (All Periods)

These may only be worn by warriors in the process of getting mail and then only for up to 12 months. Leather gambesons are the preferred option and are good to wear as armour without restriction.



# Portraying social rank

Please note that most of the evidence used is English; the system in England appears to be similar to that used in other parts of Northern Europe at the time, and is relatively well understood. In Regia's period, in England, the social rank was seen to be a twofold division of free men between the "Eorls" and the "Ceorls" - the Nobility and the Commoners. There were also a class of "unfree" - slaves. However, we can see that the picture is much more complex than that, and that some of those at the bottom of the "Ceorls" were almost as bound as those who were unfree. This section is a very simplified version of the social system – which also makes a fair amount of assumptions. Think of it as a stereotype – there are exceptions to virtually everything said below.

Regia uses three ranks. They are based on the level of freedom to move around the countryside, with the lowest on the social scale having the least ability to move, whilst the highest on the social scale can go pretty much where they like. This has been chosen as the key differential between classes because most of Regia's displays involve a large mobile population: either based around an encampment (the LHE) or an armed force (the Battlefield). Thus the three ranks are the Bound (those who are tied to the land), the Free (those who have some ability to move from the land), and the Nobles, who may move at their own will.

## The Bound

The Bound men are at the lowest level of the social scale. They make up the vast majority of the population in the Early Middle Ages.

**Beggars** were the poorest of the poor. In truth, they were free to move wherever they wanted, as well as being free to starve in a ditch. They would need to move from place to place looking for alms; they would have dreamed of being a slave.

**Slaves** were the property of their owner, be that a villager, a Freeman or a Noble. They were technically property; however, they were allowed to work a few hours a week for themselves. They were not "plantation slaves" (as was seen in the Southern United States before the American Civil War) – for instance, some had individual houses and could form families. They could even buy their freedom; however, if they had no way of supporting themselves, they would soon be reduced to beggary. If they were lucky, a freed slave would find a place in a village.

**Commoners** (Villagers, Cottagers and their Under-tenants) were the first grades of freemen. However, they would have spent about 3 days a week throughout the year working on the land of their Lord; plus they could be called upon when their Lord demanded extra work at harvest time, effectively binding them to the land. It is debatable whether they could leave

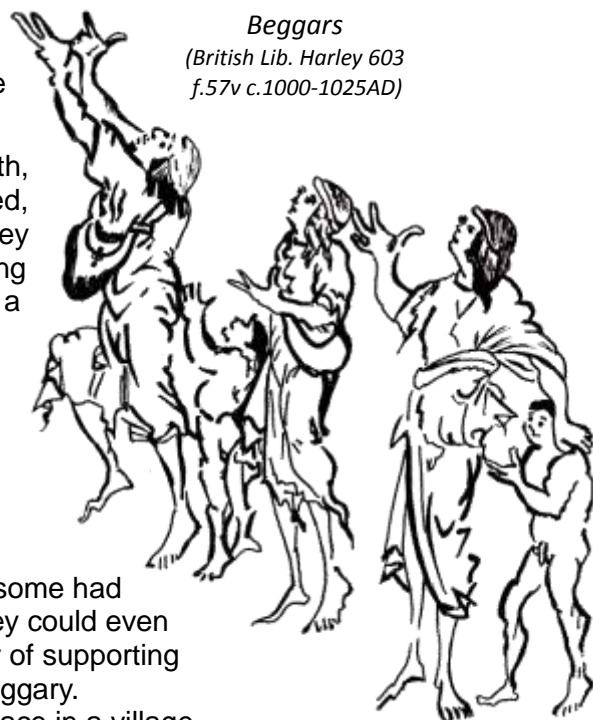

*Beggars*  
(British Lib. Harley 603  
f.57v c.1000-1025AD)

the land they farmed in their wills, sell it, or move away from it for extended periods, without the consent of their Lord. Given such restrictions, they did not “own” the land in the modern sense. However, they did have some rights over it, and were not able to have been removed from the land arbitrarily by their lord.

They also had some legal rights. They could levy a fine (or more likely get their lord to levy the fine, and get part of the compensation for it) for breach of the peace in their own holding. Some would attend the local meetings of the “hundred court” (and possibly, for those at the top of the tree, the Shire Court) where disputes with other villagers could be settled. They had a Wergild – literally a “man-price.” If they were slain, their family (and their Lord) could claim compensation for his death based on this. It also measured the value of their oath – see section 9.5 for more details.

This class did not pay “geld” - the national tax on land; it was their Lord who had to stump up the money. It was (probably) their Lord's ability to pay the tax that gave him legal (or moral) rights over the “village” land. Of course, the Lord gained his taxes (and more) from the work of his villagers. However, villagers could involve themselves in communal enterprises (such as building a mill or a fish-weir) which could be taxed.

The members of this class are likely to be under-represented at most Regia events. They “don't get out much” - most people will be working dawn till dusk on the land.

## The Free

This represents a variety of peoples who have less restrictions on their movements than the vast majority of the population. There was a small class of “Yeoman Farmers” who did not have to work on the land of a Lord – perhaps tellingly these appear (from the Domesday Book) to be more common in areas of England previously under Danish influence. There are those known (again in Domesday) as “Radcnichts” who were lords trusted servants able to run messages for their lords. The “cnicht” part of this gave us the word “knight” - but they were probably nearer to a “squire” or a “retainer” in terms of social status – and duties.

There were “free men” who could chose under which lord they wished to hold their land or give their allegiance – and these were two separate things, and could be given to two different lords. There were also a class of people called “Sokemen” who could choose with which lord (or with which court) they could seek justice. (Old English Sake is cognate with modern English “seek.”) This may have meant that they were responsible for paying their own tax on the land – admittedly via the lord to whom they have given their “soke.”

There were also folk who lived in the large (for the period!) towns in England (and so perhaps elsewhere) called “Burgesses” who were beginning to form a mercantile class. However, the Burghs (from which we get our modern “borough”) were fortified, and the Burgess's duties included the repair of the defences – and possibly manning them, too. In England, some Burgesses may have been regarded as thegns.

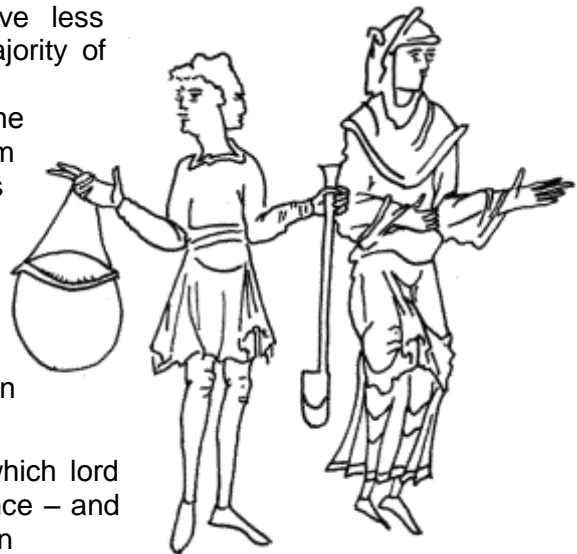

*Ceorls*

*(Oxford Bodl. Junius 11  
“Caedmon” p.46 c.1000AD.)*

## The Nobility

In the early middle ages there was one qualification essential to be a member of the male nobility: you had to fight. You could inherit nobility, or you could earn it; but neither was likely to happen if you were not available for muster. We are told that, in England, a ceorl (commoner) was “worthy of Thegn-right” if he had five hides of land, church, kitchen, bell house and “burgh-geat-setl” (possibly a house in a fortified town, or possibly a small fortification) and a special duty in the Kings hall.

In general, holding of land and military service were inextricably linked in Northern Europe. Either the King gave you land for service in war, or you held land because you served the king as a warrior. The Domesday Book tells us that in Berkshire that one “miles” was expected for each five hides – we can guess that a similar system was in place across the rest of England. Larger landholders (such as the Church) would let out land at low or no rents to thegns (who presumably did not own five hides of land – perhaps younger sons) who would perform military service for them. At the other ends of the scale, we can see thegns who have other thegns serving under them, thegns who were close enough in wealth and power to the upper levels of the aristocracy – the Earls and Bishops.

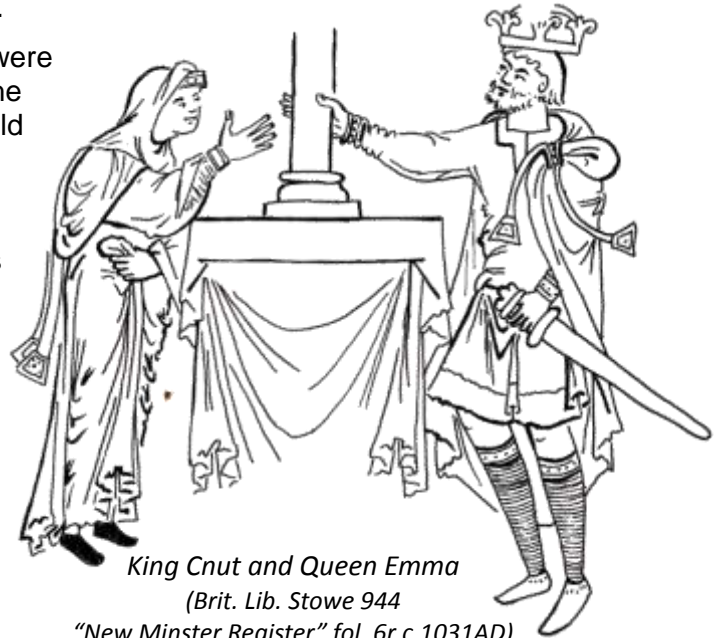

*King Cnut and Queen Emma  
(Brit. Lib. Stowe 944*

*“New Minster Register” fol. 6r c.1031AD)*

### Organisation of Land and Armed forces

England will be taken as a template for the organisation of a country. The standard unit of measurement was a “hide”, with each hide at least nominally able to support one household. Five hides were expected (at least in 1066) to produce an armed and armoured warrior – with possibly a retainer equipped with just a spear and shield. A hundred hides were grouped into a unit – called a Hundred (oddly enough) or a Wapentake in the North, which would therefore be expected to provide about 20 warriors. There would also be “hundred moots” or hundred courts. Each shire would have a number of hundreds – between 4 and 32, and have a central town – a Burgh. Shires were run by Earls (Eorls or Ealdormen) – originally one per shire, but as Earls became more powerful they took over more shires; the main business of administering a shire was done by a shire-reeve (called sometimes in Domesday Viscomes, Vice-Count.) Note that under Norman rule, each shire was given (nominally, again) to a Count – which is why they are often called “Counties.”

### Law in 10<sup>th</sup> and 11<sup>th</sup> Century England

In England, as in much of northern Europe, the legal system differed vastly from modern times. There were no police, no prisons, and no judges. There were courts – held at hundred meetings or shire meetings. Ten men would take an oath promising that if one of them was required to be at court, they would all make sure that he got there – even if he didn't want to go. Someone accused of a crime would take an oath denying it, along with several “oath helpers.” The power of the oath was based on the value of their wergilds. If this proved to be unsatisfactory, a trial by ordeal could give “the judgement of God.” The penalty could be a flogging, mutilation or even execution, but a fine seems to be the most common. One part of the fine was based on the wergild of the aggrieved parties, and went to them – or their families in event of murder. Another part – the man-bot – was based on the wergild of the aggrieved party's lord, although the King usually got a cut.

## Approximate equivalent ranks

Noble		Free		Bound		Grade	Names	Clothing notes [2]	Colours [2]		Wergild						
RICH		Average		POOR					Clothes	Decoration							
Earl	Lord	Warrior	Knight	Yeoman	Villager	Cottager	Under-tenant	Slave	Beggar	Modern	English [1]	Viking [1]	Norman	Perhaps Hooded "poncho" - or patched cast-offs	Natural Colours	None	(None)
Eorl/ Eolderman	King's thegn	Thegn	Geneat	Ceorl	Tunsmann	Kotsetla	Boor/ Gebur	Theow		English [1]				Tunic, leg bindings, cloak; coarse wool or linen – perhaps decorative stitches	Yellow, moss green	Yellow, moss green	Note [3]
Jarl	Styraesman/ Landmann	Thegn	Dræng	Bondi	Landbo		Garthsæte	Thrall					As above plus trousers / hose and braies				
Count/ Duke	Baron	Miles	Radcnicht	Ceorl	Villein	Bordar/ Cotar	Colibert	Serf					As above, decorated hem on cloak, embroidered seams; fine weaves	Stronger reds or blues	Stronger reds or blues	Stronger reds or blues, "fake" woollen fur. Bronze fittings	200 – 600 English shillings Ceorls
													Decorated tunic; different dyes for warp and weft threads				
														Full length robe, figured cloth, silk	Kermes red	True purple, gold fittings	1200 shillings (Eorls)
													As above, contrasting facings or tablet weave at neck and cuffs, simple embroidery; close weave material				

Notes: [1] The English preferred to wear Red, the Vikings preferred blue.

[2] This indicates the "poshest" that can be worn – poorer items may be substituted

[3] In general a slave was not "oath worthy" - their word did not count in law. To free themselves they could pay over their purchase price – in the order of 30 silver pennies. If they were killed, their owner got 20 shillings compensation, whilst their families got 40 pence



# The Wic

## New for 2015

### New Unacceptable items from 1st January 2015:

*These have completed their 12 months' notice. The intended phasing out of these items was published in the previous AO regulations. They have completed their 12 month notice period and any amendments have been included in the descriptions below.*

#### **No single-piece blacksmith (Viking women's style) knives**

*These are a re-enactment created item from the 1980's. Their nearest archaeological equivalent can be found from Iron Age Danish bog finds (c.500BC).*



**Unacceptable** 'Viking woman's knife'

## Tents

### AO Special Mention:

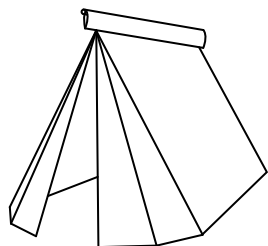

**More Saxon Style end-opening tent with 'ears'**

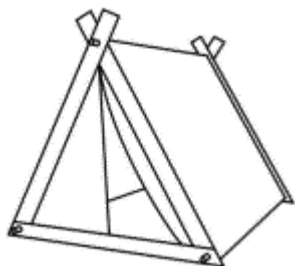

**Less Viking Style tents after 980AD**



**More painted tents**

#### **More end-opening tents**

Tents from Regia's period were end opening and our tents should reflect this.

Although side opening tents are inauthentic they remain allowable as it is felt that they add value to the event by allowing the public to see more of the contents. But to fully achieve this they should be well dressed.

#### **More substantial 'ears' on Western European style tents**

Depictions of these tents show a band running along the ridge and ending in large 'ears'. All tents except for Viking and Bell style tents must have 'ears'. When you are looking for a new tent, look out for this feature.

#### **Less Viking style tents after 980AD**

Viking style tents seem to be very early. Although they are allowed at all Regia events it would be nice not to see them at events after 980AD.

#### **More Painted tents**

Many of the depictions of tents from Regia's period show them having coloured panels. It is likely that these expensive tents would have been decorated in this way.

Tent canvas can only be painted in approximately 450mm (18") stripes using a maximum of two colours (not counting the canvas colour). Decoration along the ridge panel may be applied using a different third colour but must be based on the decoration seen on tents in contemporary manuscripts.

Tents must only be painted in colours that were easily available and relatively cheap in Regia's period. So whites, yellows and reds are good. Green earth (a soft dull green) is ok. Blues, blue-greens and purples must never be used.



**No visible metal eyelets on tents**

Any metal eyelets on tents or work shelters should be hidden. For example by covering them with a leather patch or by whip stitching around them.

**No visible metal collars on tent or work shelter poles**

Obvious metal collars on tent and work shelter posts must be disguised. They should be painted to blend in or otherwise hidden

**Metal tent pegs**

Although metal pegs may have been used, wooden pegs would have been the norm. For safety reasons 4 metal pegs can be used, one at each of the tents corners. These metal pegs must have a blacksmith produced look. Galvanised modern tent pegs must never be used anywhere visible.

## Other Items



*A glass beaker  
(Museum of London A15272  
H. 82mm DM (rim) 62mm  
C8<sup>th</sup>-C10<sup>th</sup>)*



*Less pottery cups  
This pottery Jar or cooking pot could  
have possibly doubled as a cup.  
(Museum of London A23547  
H.83mm DM 100mm)  
C10<sup>th</sup>-C11<sup>th</sup>*

**AO Special Mention: Less pottery cups**

The use of pottery cups during Regia's period seems to have been quite rare. To this end it would be better for pottery cups to be kept to the back of the wics and not left prominently on display in front of the public.

It is also worth noting that much of the pottery of the period was unglazed. Regia allows the use of glaze on the inside of pottery and around the outside of the rim for safety reasons. Glazing on the outside of pottery should only be used for replicas of Stamford ware and other glazed pottery with provenance.

**AO Special Mention: Less sash cord**

Although window sash cord is readily available and looks ok from a distance, proper rope looks much better and lends itself to being authentically spliced.



*Less Sash Cord*



*More Authentic Rope*



This section explains the thoughts behind and the aim of two new terms being introduced, **Battlefield Authentic** and **Armoury Authentic**. The end goal being a more authentic and educational Armoury display, without limiting what weapons and armour members can use during training and battle displays.

### Battlefield Authentic

Battlefield Authentic refers to the level of authenticity expected to be achieved by members while taking part in Regia military displays at events. This is an attempt to allow as many people as possible on the field, especially in the extended periods, without them having to buy new expensive equipment for each dateline. By keeping the rules for Battlefield Authentic equipment more relaxed it is hoped this will increase the number of combatants on the field and make sure everybody can enjoy their hobby.

Armour and weapons are considered battlefield authentic if they are:

- Look reasonably authentic to the given dateline, while in use on the battlefield, at a range of about 10m.
- They are generally in the 'Allowable' column in the 'Authenticity Kit Guide', for the show dateline, and comply with the current MaA regulations.

Items that are Battlefield Authentic but not Armoury Authentic should:

- Not be displayed on the armoury
- Be known by the wearer to be 'wrong' so it can be explained by them in case they are asked by a member of the public.

Some examples of battlefield authentic items:

- Swords suspended from sword belts in early period shows, and swords on baldrics at later datelines.
- Gloves.

This is no excuse to mix kit from various periods. All of a warrior's kit should be consistent within itself. The higher ranking a person you are displaying, the more correct your equipment should be.

### Armoury Authentic

Armoury Authentic refers to the standard of authenticity expected to be found on an LHE armoury display during a Regia event. The primary goal of an armoury display is to educate about the correct appearance, nature and use of the arms and armour of the dateline portrayed. This level is higher than that of Battlefield Authentic, mostly because the weapons used for combat have to be denatured to be safe. We have got the correct equipment within the society which should be highlighted and used to educate away from the battlefield. We realise that it is early days, but it would be nice to see good quality, authentic equipment being made and purchased specifically for its use on a quality armoury display.

Armoury Authentic arms and armour are:

- In the Encouraged or Optional columns of the AO kit guides.
- Period specific weapons and armour including helmets.
- Correct scabbard styles and suspension method for swords and knives.
- Riveted mail, of the correct period style.
- Can be Semi-sharp or sharp, but good examples of blunt weapons should also be available to allow the public to handle them.
- Blunt weapons should still be of a more authentic shape, weight and size than those used on the battlefield.
- Correctly sized, and if possible correctly constructed equipment (i.e. large, planked, leather covered shields).
- Run by a person knowledgeable in the equipment and its use in the period, as well as being able to highlight the difference between what would have been used then and what we use today in our military displays.

## Previous Authenticity Rulings

The following list is a history of previous Authenticity rulings. Some rulings have since been superseded or repealed and are labelled as such. Those that are still current are marked as [current]. The descriptions have been abbreviated and modern terminology used.

### 1991-Andy Nicholson

1. No front and back style 'apron' Hangerocks [Current].

### 1992-Members Handbook

2. Black leather or fabric may only be used by the incredibly wealthy [Partially revised].
3. No man made fabrics [Current].
4. No furry leggings [Current].
5. No leather clothing except aprons for blacksmiths, bronze caster and the like [Current, but see leather hose revision].
6. All knives and swords must be scabbarded [Current].
7. All arrows must be carried in a quiver [Current].

### 1992-Clamavi Mar/Apr, Andy Nicholson

8. No chrome or square belt buckles [Current].
9. No plaid cloth [Current].
10. No side sewn or thronged sword scabbards [Current].
11. No green, red or black welding gloves [Current].
12. No pseudo-medieval costume jewellery [Current].
13. No ear rings, nose rings, makeup, visible dyed hair, visible bleached hair or modern socks [Current].
14. No women who look female when in male kit [Repealed and revised to 'women must try and look as masculine as possible when fighting in male kit'].
15. No shoe uppers made from different coloured leather [Current].
16. No cross gartering for non-Normans [Current].
17. Shield colours and designs restricted by rank [repealed, now revised].

### 1993-Clamavi Mar/Apr, Andy Nicholson

18. No English wearing long boots [Current].
19. No shoes with lacing up the front or side [Current].

### 1995-Clamavi 26, Sarah Gilchrist

20. Viking tunics must reach at least to mid-thigh when belted [Current].
21. Saxon tunics must reach the knee [or slightly above] when belted [Current, modified].
22. Dresses must reach the ankle all the way round when belted [Current].
23. Dresses worn by women of child bearing age should have the appearance of allowing breastfeeding [repealed].

24. Men with inauthentic hair styles must wear a hat/hood/helmet/coif/arming cap [Current].

25. All warriors using a sword must be wearing either a gambeson or mail armour [repealed].

### 19??-??, Sarah Gilchrist

26. Women warriors must either wear their hair in a ponytail or wear a hood [repealed].

### 1996-Clamavi 27, Sarah Gilchrist

27. Silk is limited to use by the church and the RICH for caps, ribbons, trimmings and maybe the occasional wimple [Current].
28. No purply-pink types of Brazil wood dyed cloth [Current].

### 1997-AO Report, Sarah Gilchrist

29. No visible machine stitching [Current].
30. No large penannulars (over 2" or 50mm) post 1000AD [Current].
31. Women wearing hangerocks may only have one string of beads between the brooches except for those portraying a RICH woman who may have two [Current].

### 1998-MAA Report, Dave Pateman

32. No mail shirts that are too short to cover the wearer's crotch or that have sleeves that are too short to cover the wearer's elbow when the arm is held straight out [Revised to allow shorter mailshirts before 900AD].
33. No poached egg shields [Current].
34. No flat kite shields [Current].
35. All kite shields must have a boss [Partially revised, after 1180AD bosses are not needed].
36. Padding does not have to be worn under a mail shirt [Current].

### 1998-Chronicle 50, Roland Williamson

37. No wide leather belts (over 1½") [Partially revised, now 'typically no wider than 25mm'].
38. No English men's tunics that don't reach the knee when belted [Partially revised to 'knee level or to within 2" above the knee when belted'].

### 2000-Chronicle 57, Roland Williams

39. No Phrygian style hats [Current].
40. No Viking fur brimmed hats [Current].
41. No exposed leather pouches or box pouches [Revised by Gary Golding for Birka style pouches in context] [Stephen Etheridge modified it to 'small hooked/drawstring pouches OK – one per person – about the size of a fist – based on York/Vatican finds']



## 2004-AO Report, Steve Etheridge

42. Tunics are to be able to come down to the knees [Partially revised to 'knee level or just above the knee when belted']
43. The shirt (undertunic) should (before the 12<sup>th</sup> century) be shorter than the tunic [Current].
44. Women's dresses should be ankle length all the way round – not just at the front [Current].
45. All tunics and dresses to be made out of substantially the same fabric. This means that the arms and darts should really be cut from the same cloth as the body. Separate colour trims may be applied to neck, cuffs and (more rarely) hems [Current].
46. All modern brass eyelets on tents and other fabrics are to be removed or concealed [Current].
47. New striped tent canvasses will be allowed only after consultation with the AO and the LHE Co-ordinator [Revised to allow anyone to have a painted tent in up to 2 colours].
48. Metal axe loops on belts to be removed – fabric or leather ones to be used instead, or the axe handle can be put through the belt [Current].



## 2005-MAA Regulations, Nigel Amos

49. No kite shields without bosses [Partially revised, after 1180AD bosses are not needed].
50. No round shields curved in a single plane [Current]
51. No mail shirts that are too short to cover the wearer's crotch or that have sleeves that are too short to cover the wearer's elbow when the arm is held straight out [Revised to allow shorter mailshirts before 900AD].

52. Mail shirts that are constructed from galvanised or zinc coated steel rings should have the zinc layer removed [Current].

## 2005-AO Report, Steve Etheridge

53. Adult clothing must be made out of substantially the same fabric. Children's garments can be extended using other fabrics [Current].
54. Leather arm or leg protection ("greaves" and "vambraces") should not normally be seen [Current].
55. Decoration on clothing should attempt to reflect in style and materials the status of the garment to which it is applied and the person wearing that garment [Current].

## 2006-AO Report, Steve Etheridge

56. No Hangerocks without tortoise brooches [Current].
57. No mail shirts with open armpits [Current].
58. No bare pine on the LHE. Pine must be painted or otherwise disguised [Current].
59. Don't throw rugs over obvious modern furniture to hide it [Current].
60. No shoes with two or more lace holes up the front [Current].
61. No floppy loose trouser legs [Current].
62. Men's shirts (under tunics) must not be seen at cuffs or hem [Current].

## 2007-Chronicle 74 p.15, Steve Etheridge

63. Dane axes can only be used between 980AD and 1016AD by Vikings [Current].

## 2002-2008, Steve Etheridge

### unpublished, but widely known, rulings

64. No Saxon women wearing leather buckled belts (Detling 2006) [Current].
65. No Saxon women wearing scarves worn on the head, secured by tablet woven bands worn outside the scarves (Fritton Lake clothing meeting) [Current].
66. No items found only from Gotland unless representing a character from Gotland and wearing 100% accurate Gotland kit [Current].
67. No contrasting hems on men's tunics (Steve Etheridge – Whitby) [Revised to Allowable after 1041AD].

### Other pre 2012 rulings with unknown publication dates and that are currently enforced

68. Women on the battlefield must dress convincingly as men [Current].
69. No Saxon women having their hair uncovered [Current].
70. Bell tents can only be used by the Clergy [Current].
71. Saxon style tents can only be painted in two colours [Current].
72. No Viking men's baggie trousers tied at the ankle [Current].

73. No Nálebound (beanie) hats [Current, revised to allow babies and maritime sailors wearing them only].
74. No painted scabbards [Current].
75. No tall Boots (over 1/3<sup>rd</sup> of the way up the leg) [Modified to not above ankle bone]
76. No tablet weave, embroidery or inkle-woven braid made with thick wool or 3 ply wool [Current].
77. No rich purple cloth outside of high ranking ecclesiastical kit [Current].
78. No men wearing necklaces with more than two beads on [Current].
79. No "sausage plait" style of head covering, where a scarf is tied down the length of a ponytail with a criss-cross of braid [Current].

### Regia AO Regulations 2012, Gary Golding

80. No cloaks with a different coloured lining or made from panels of more than one colour. [Current]
81. No braid (tablet, woven, etc.) made from thick wool can be used. This includes for decoration or for belts [Current].
82. Leather hose may only be worn by Regia members who are riding a horse at that event or, alternatively, by members wearing authentic style spurs when not on the battlefield. Horse riders would normally be considered RICH [Current].
83. No C12th style laced boots over the top of the ankle bone before 1042AD. Toggle style boots may however be worn pre 980AD [Current].
84. No unworked antler handles. The rough natural surface must be removed and the handle may be decorated with ring and dot or simple geometric patterns [Current].
85. No 'Celtic' style knot work patterns on shields. Appropriate Viking art styles may be used if approved by the AO first [Current].
86. No brooches worn at the neck for men. The use of discreet ties is encouraged instead and small hook and eye clasps are allowable [Current].
87. Women must not wear just a cap or headscarf as a head covering when walking

around the LHE. Headscarves are allowed to be worn when working in the Wic (in the home). When away from the Wic women should wear a wimple or veil [Current].

88. Women must not secure their wimples or veils with tablet weave, string or braided ties. Wimple pins should be used instead [Current].
89. If a mantle is worn, it must be worn under the wimple or veil (scarf) [Current].
90. Obvious metal collars on tent and work shelter posts must be disguised. They should be painted to blend in or otherwise hidden [Current].
91. Tent canvas can only be painted in approximately 450mm (18") stripes using a maximum of two colours (not counting the canvas colour). Decoration along the ridge panel may be applied using a different third colour but must be based on the decoration seen on tents in contemporary manuscripts [Current].
92. Toggles on shoes must be made only from leather. Bone, wood, glass or antler toggles should not be used [Current].
93. Leather should not be dyed anything other than brown, except if used for high status items and then only red dye should be used. Leather should also not be left as pink Veggie Tan. Efforts should be made to darken the leather by oiling or waxing [Current].
94. No porches should be added to any new period tents [Current].

### Regia AO Regulations 2014, Gavin Archer

95. No long tunic (man dresses), that come to below the knee, before 1042AD [Current].
96. No wide tunic facings over 8cm (3") wide before 1042AD [Current].
97. No single-piece blacksmith (Viking women's style) knives [Current].
98. No mail covered combat gloves. Attached mailed mittens are allowed after 1080AD [Current].

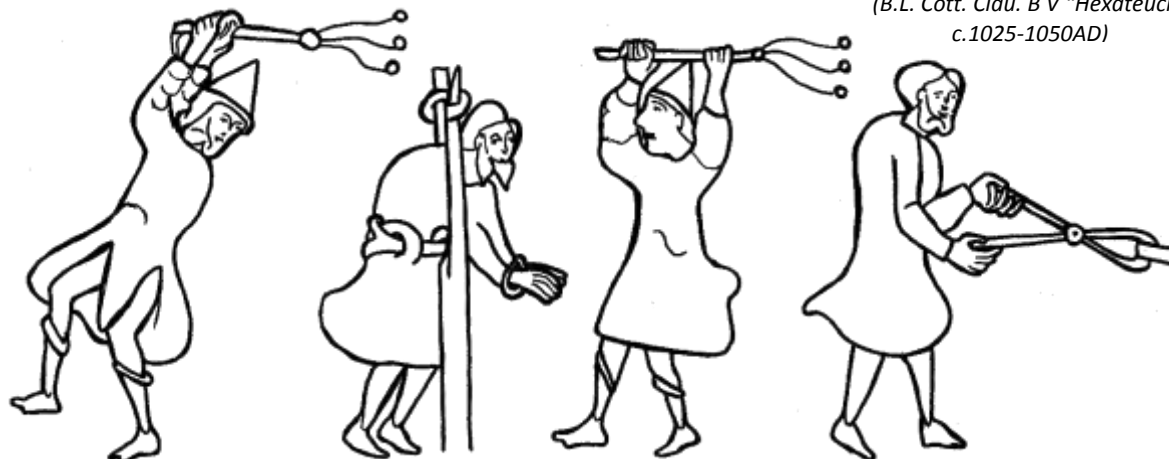

*(B.L. Cott. Clau. B V "Hexateuch" c.1025-1050AD)*

# The Kit Guides

The intention of this chapter is to provide Regia members with a simple set of guides to assist them in knowing what items of kit are appropriate for certain datelines. They cover all six of Regia's periods and it is hoped that members will use them in the spirit in which they are intended, and not to seek to exploit 'loopholes' or push the boundaries of authenticity using the information they contain.

It is the intention of these guides that all items that are classed as Encouraged or Optional have either numerous provenances or alternatively come from well researched interpretations. Items with only a couple of provenances or more contentious interpretations are classed as Allowable.

Items listed as [R] are of very specific and restricted use and you should check against the Restricted pages (found at the end of Womens Clothing, Mens Clothing or Warriors chapters) to ensure that you can use them.

Items listed as RICH mean very high status items, strictly reserved for the noble classes; Thegns, Eorls, Barons, Dukes, high Church, Æthelings and Kings.

Underlined items are new items classed as strictly 'Unacceptable' from the beginning of 2015.

*Italic* items have been changed since the previous set of regulations.

## Jewellery

This year image plates have been added showing clothing style and recommended associated jewellery. Currently Regia does not authenticate art styles in regards to jewellery although we do insist on jewellery being the correct shape. So for example, a disc brooch can be used in all periods no matter what its art style but Viking oval brooches can only be used before 980AD. It is hoped that those members who own multiple pieces of jewellery will attempt to wear the appropriate items when and where they can.

Please remember that ALL items must be worn in context to the character's social rank and ethnic background being portrayed.

Avoid mixing and matching kit from different areas and cultures.

Where sizes are given they are approximate only and will vary somewhat depending on the wearer's own size.

Note that items listed as [R] are considered restricted.

If something you would like to make or wear does not appear in the Event Kit Guides then check before making or wearing it for an event.

**If in doubt about any item of kit please check with the Authenticity Officer first.**

  
**Regia Anglorum**  
**Generic Kit (793-1215AD)**



*Dress Style 1  
with a veil  
style of head  
covering*

*Dress Style 2  
with a wimple  
style of head  
covering*

**Generic Clothing – All Periods (793–1215AD)**

**Women**

**Men**

	<b>Encouraged</b>	<b>Optional</b>
<b>Head</b>	Wimple or veil over a cap, headscarf or wide headband and that shows the throat	Headscarf Cap Hood
<b>Under Shirt</b>	Shift made from linen with a bias edged keyhole or oval neck hole Natural linen	Tight sleeves with rucking Dyed a light colour or bleached
<b>Dress \ Tunic</b>	Woollen ankle length dress with keyhole or oval neck hole Tight or loose sleeves	Dress sleeves to mid forearm
<b>Belt &amp; Bags</b>	No belts or girdles	Braided textile belt Cloth sash in same material as the dress Split end leather belt Leather or cloth satchels or sacks Small drawstring pouch
<b>Cloak</b>	Rectangular cloaks fastened with ties Hanging length from knee to mid shin	Clasped at the chest with disc brooch Pinned with ringed pin, penannular Edged with different coloured facing
<b>Legs</b>	Bare legs	Trousers or hose if hidden Leg bindings
<b>Shoes</b>	Low shoes or ankle boots (to bottom of ankle bone) Bare feet	Nålebound socks

	<b>Encouraged</b>	<b>Optional</b>
		Hood
	Natural or bleached shirt made from linen with a bias edged keyhole or oval neck hole Side split	Shirt made from wool Dyed a light colour Shirts with skirt gores Square neck holes
	Tunics made of wool Rucked up to knee length with tight rucked sleeves Keyhole or oval neck hole with bias edging	Tunics made of linen Neck hole closed with ties Tunics with hems that end up to 2" above the knee
	Buckled leather belt or cloth tie hidden by tunic Small knife in sheath	Split end leather belt Leather or cloth satchels or sacks Small drawstring pouch
	Rectangular cloaks pinned at shoulder with disc brooch, ringed pin or penannular Hanging length from waist to knee	Edged with different coloured facing
	Wool trousers or hose tight to legs Bare legs	Leg bindings worn spirally around the lower leg Trousers or hose with integral feet
	Low shoes or ankle boots (to bottom of ankle bone) Bare feet	Nålebound socks





Open Palla

English Costume



Closed Palla



Hangerock Set

Dublin Scarf

Viking Costume



English Jewellery

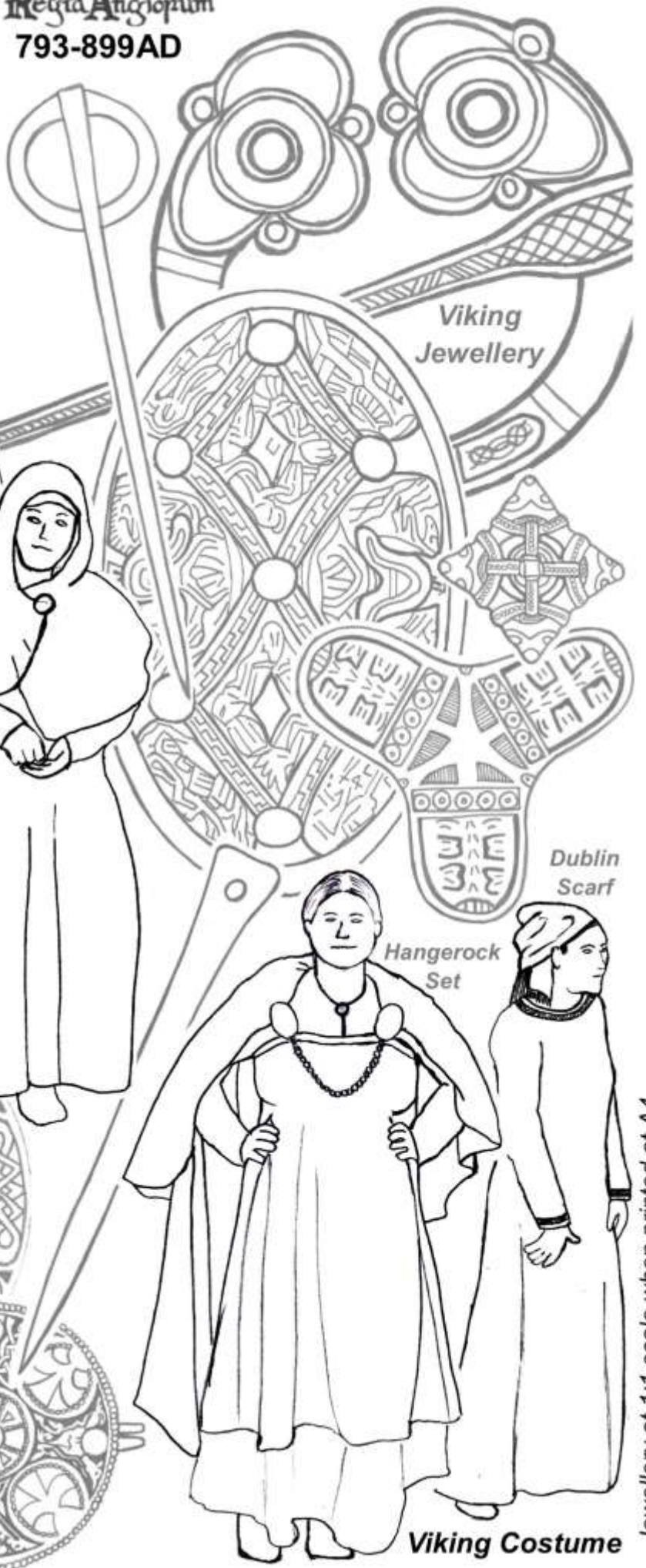

Viking Jewellery

**Women's Clothing – Very Early (793–899AD)**

	<b>Encouraged (Very Common)</b>	<b>Optional (Less Common)</b>	<b>Allowable (Interpreted or Rare)</b>	<b>Unacceptable</b>
<b>Head</b>	Palla [E] Veil over a cap, headscarf or wide headband and that shows the throat [E] Dublin scarf with hair showing in an authentic style [V] Cap with hair showing [V]	Bareheaded long hair (past shoulder) [V] Bead necklace [V]	Headscarves [POOR] Hoods [POOR] Wimple over a cap, headscarf or wide headband [E] Sprang hair net [V]	Bareheaded women / teenage girls [E] Obviously dyed hair Makeup Any tie or fillet worn over the head covering Veils with long tails
<b>Under Shift</b>	Shift made from linen with a bias edged keyhole or oval neck hole Natural linen	Tight sleeves with rucking [E] Pleated shift [V] Small brooch at throat[V] Dyed a light colour or bleached	Different colour square or round facing Dyed a strong colour Embroidery [RICH] Short visible shift, just above the ankle [POOR]	Other decoration Visible Shift above mid-calf Brooch at throat [E]
<b>Dress</b>	Woollen ankle length dress with keyhole or oval neck hole Tight or loose sleeves Embroidery [E][RICH] Wool or linen hangerock to mid shin (must be worn with oval brooches) [V]	Dress sleeves to mid forearm [E] Beads between oval brooches [V] Decorated with: - Decorative seams - Braid - Tablet weave (1 to 3 colours) - Brocaded tablet weave [RICH] - Embroidery [E] [RICH] - Silk ribbons [RICH]	Dress made from linen Decorated hem with an embroidered facing or braid [RICH] <i>'Decorative' brooch [RICH]</i> <i>Dress to mid forearm and mid shin with no visible under shift [POOR] [R]</i>	Dress to mid shin (must be worn with ankle length shift) Norman style dress Dress above mid-shin Different coloured gores or sleeves Other decoration including chunky wool
<b>Belt &amp; Bags</b>	No belts or girdles	Braided textile belt Cloth sash in same material as garment worn with - dress or mantle [E] Leather or cloth satchels or sacks <i>Drawstring pouch</i> <i>Small knife in sheath [V]</i>	Woven textile girdle Hidden leather tie belt Small drawstring or tagged pouches Forged snips in sheath <i>Small knife in sheath [E]</i>	Chunky wool girdle Leather belts with buckles Box pouch Modern snips or scissors
<b>Cloak</b>	Cloaks clasped at the chest with disc brooch Pinned with ringed pin, penannular [V]	Edged with different coloured facing Backtrain suspended from oval brooches [V]  Pinned with trefoil >850AD[V]	Mantles [E] Hooded cloaks Long jackets (With brooch) [V] Cloak pinned with pin or penannular	Cloaks pinned at hip Different coloured lining
<b>Leg</b>	Bare legs		Trousers or hose if hidden Leg bindings	
<b>Shoes</b>	Low shoes or ankle boots (to bottom of ankle bone) Bare feet	Nålebound socks [V]	Ankle boots (up to top of ankle bone) [V] Nålebound socks [E] Foot wraps or sock bags Footed hose or half hose	Tall boots (higher than top of ankle bone) 12 <sup>th</sup> C. or later patterns 8 <sup>th</sup> C. or earlier patterns

[R]= Restricted; [E]= English; [V]= Viking; [N]= Norman; [RICH]= Thegn / Odalsbondi / Hauldr ; [POOR]= Bonded / Serf / Slave



Regia Anglorum  
793-899AD

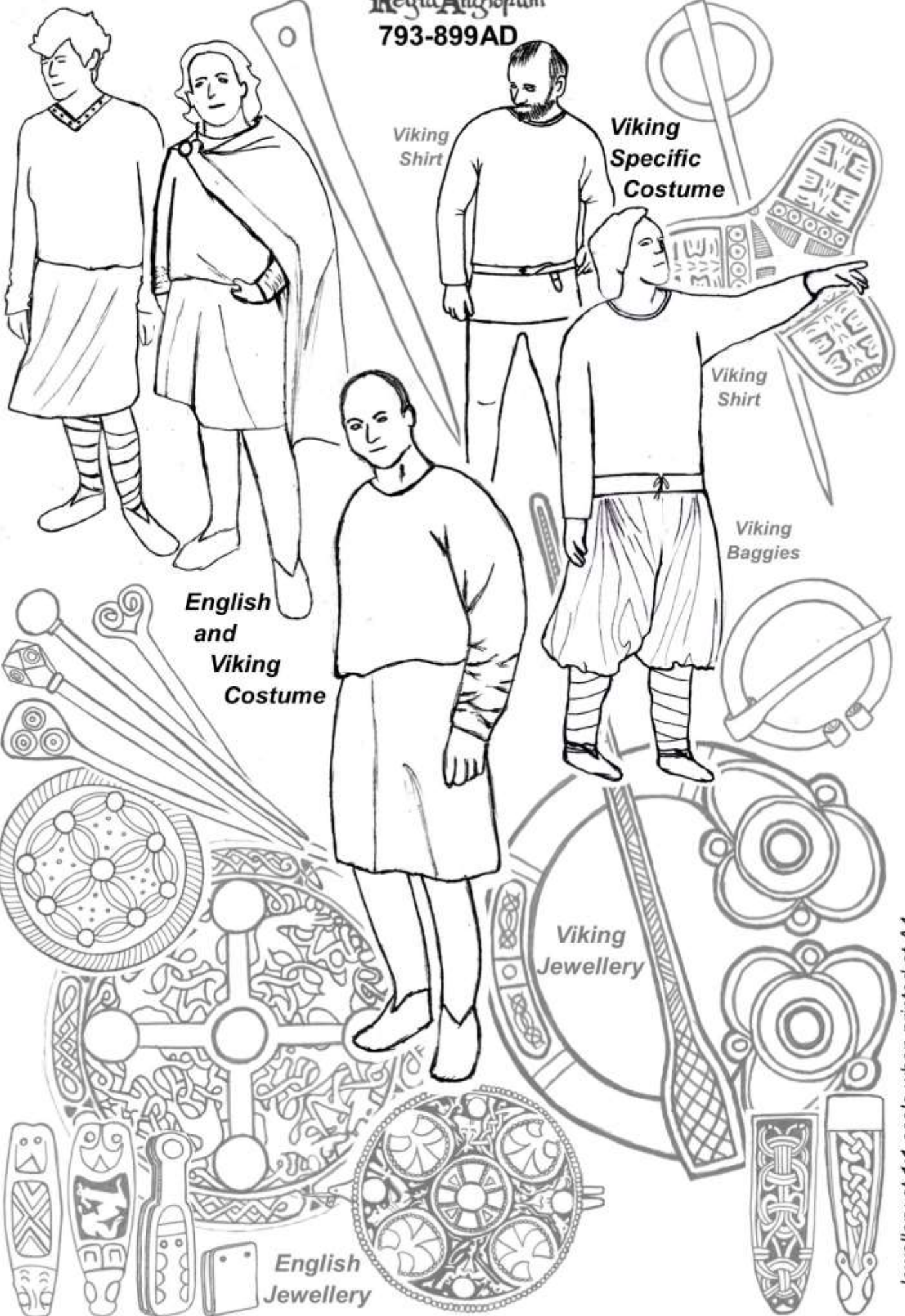

Viking  
Shirt

Viking  
Specific  
Costume

Viking  
Shirt

Viking  
Baggies

English  
and  
Viking  
Costume

Viking  
Jewellery

English  
Jewellery

**Men's Clothing – Very Early (793–899AD)**

	<b>Encouraged (Very Common)</b>	<b>Optional (Less Common)</b>	<b>Allowable (Interpreted or Rare)</b>	<b>Unacceptable</b>
<b>Head</b>	Bare headedness	Wool hoods	Linen or leather hoods Skull caps Necklace with 2 beads Straw hats [POOR][R] Frisian caps [R] Birka style hats with fittings [V][R]	Cloth "Phrygian caps" Obviously dyed hair Bead necklaces Nålebound caps [R] Fur caps
<b>Under Shirt</b>	Natural or bleached shirt made from linen with a bias edged keyhole or oval neck hole Side split	Shirt as outer garment <i>with hem ending up to 2" above the knee</i> Shirt made from wool Dyed a light colour Shirts with skirt gores Square neck holes	<i>Shirt as outer garment tucked into trousers [V]</i> <i>Short shirt as outer garment [V]</i> Different colour round or square facing Dyed a strong colour Embroidery [RICH]	Shirts visible below tunic Front split Other decoration
<b>Tunic</b>	Tunics made of wool Rucked up to knee length with tight rucked sleeves [E] Shorter tunics un-rucked to knee length with tight sleeves and no rucking [V] Keyhole or oval neck hole with bias edging	Tunics made of linen Neck hole closed with ties Decorated with: - Decorative seams - Braid - Tablet weave (1 to 3 colours) - Brocaded tablet weave [RICH] - Embroidery [E] [RICH] - Silk ribbons [RICH] <i>Rucked tunics with hems that end up to 2" above the knee</i>	<i>Shorter tunics un-rucked to mid-thigh [V]</i> Tunics with faced round or square keyhole style neck holes Tunic closed with authentic hook & eye fastener Side split [R]	Front split Loose sleeves Shorter than 2" above knee level when unbelted Brooch worn at throat Different coloured gores or sleeves Decorated with: - Chunky wool - braid/facing around hem
<b>Belt &amp; Bags</b>	Buckled leather belt or cloth tie hidden by tunic [E] Small knife in sheath	Visible buckled leather belts or cloth tie [V] Leather or cloth satchels or sacks <i>Drawstring pouch</i>	Visible buckled leather belts or cloth ties [E] Split end leather belts Belts with metal plates [V] Birka style pouches [V][R] Drawstring or tagged pouches worn on belt	Belts knotted around the buckle Long hanging belt end Chunky wool belt Box pouches
<b>Cloak</b>	Rectangular cloaks pinned at shoulder with disc brooch [E] Hanging length from waist to knee	Pinned with metal or bone pin or metal penannular [V] Edged with different coloured facing Wrap around jackets [R][V] Cloaks with tassels	Cloaks pinned at chest Fur or piled wool lining Long buttoned jacket [R][V] Pinned with penannular Cloak ribbons [V][RICH] Different coloured linings [RICH][R] Hooded mantle [POOR][R]	Mantles Different coloured lining Leather or fur cloaks
<b>Legs</b>	Wool trousers or hose tight to legs with leg bindings Trousers or hose with integral feet Bare legs [POOR]	Wool trousers or hose tight to legs with no leg bindings Loose legged trousers or baggy trousers to knee [V]	Linen trousers or hose Tight leather hose worn with spurs [RICH] Elaborate ties or leather garter below knee [RICH] Braies worn on their own	Loose legged trousers [E] Cross gartering Baggy trousers tied at the ankle
<b>Shoes</b>	Low shoes or ankle boots (to bottom of ankle bone) Bare feet	Nålebound socks [V]	Nålebound socks [E] Carolingian 3 toggled tall boot [V] Foot wraps or sock bags	Tall boots (higher than top of ankle bone) 12 <sup>th</sup> C. or later patterns 8 <sup>th</sup> C. or earlier patterns

[R]= Restricted; [E]= English; [V]= Viking; [N]= Norman; [RICH]= Thegn / Odalsbondi / Hauldr ; [POOR]= Bonded / Serf / Slave

Regia Anglorum  
793-899AD

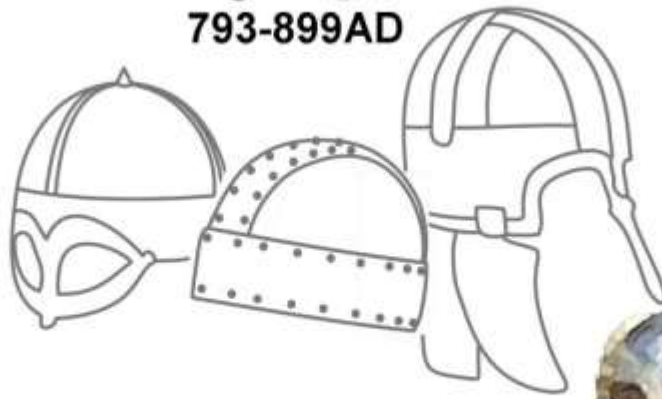

Viking Weapons

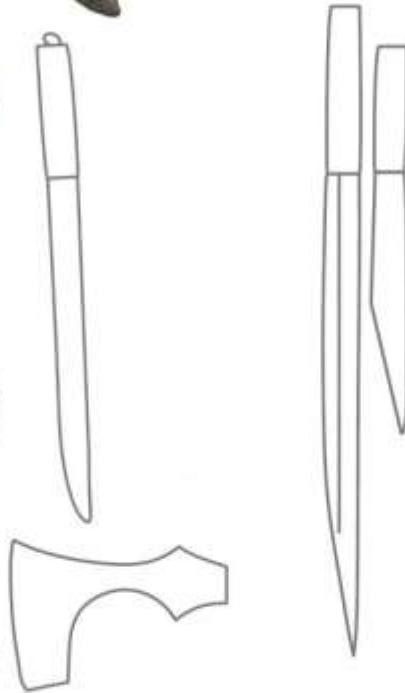

English Weapons

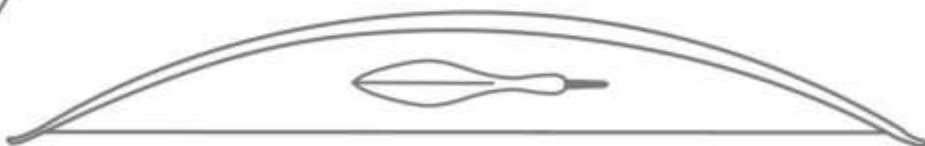



**Wargear – Very Early (793–899AD)**

	<b>Encouraged (Very Common)</b>	<b>Optional (Less Common)</b>	<b>Allowable (Interpreted or Rare)</b>	<b>Unacceptable</b>
<b>Helm</b>		Coppergate helms [E] Spectacle helms [V] Domed helm – riveted Helms with aventails Helms without nasals	Vendel / Valsgarde helm Boar crested helms Conical helm – riveted panels Hardened leather caps	Great Polish helm Conical helm – ‘single piece’
<b>Armour</b>		<i>Mail shirt length from just below the waist to knee [RICH]</i> Unsplit or side split 6 - 8mm alternating riveted & welded 6 - 8mm riveted	Vandyked mail shirt Leather jack, leather or cloth padded gambeson worn under mail Leather jack or leather padded gambeson worn as armour <i>Cloth padded gambeson worn as armour [R]</i> Butted / riveted links up to 10mm <i>Simple leather gloves</i>	Mail shirt with integral coif Separate coif Front split mail shirt Splinted arms or legs Lamellar / Scale Cuir Bouilli / Plate <i>Mail covered gloves</i>
<b>Shield</b>	<i>Large round shields that extend past the elbow by 2" or more</i> Flat round shields [V] Lenticular shields [E] Sewn on leather or rawhide edge Painted in a single colour	Smaller shields that don't cover the elbow Flat round shields [E] Nailed on leather or rawhide edge Painted in a cross [E] or radiating curved lines [V] Painted in up to 3 colours	Painted in Oseberg, [V] [RICH] Painted in Trehwiddle art style [E][RICH] Painted in other simple geometric design Painted in 4 or more colours [R]	Kite shields Unbossed shield Rectangular or oval shields Painted in Celtic knotwork Painted in other art style or design
<b>Spear</b>	1-handed spears Leaf shaped heads	<i>2-handed winged spears with blade of 8" – 16" [after 1/1/2017]</i> Angular shaped heads	<i>2-handed spears with blade of 8" – 16" [after 1/1/2017]</i>	Angon
<b>Knife</b>	<i>Seaxes with blades from 7" to 10"</i> Wood Handles Decorated knife sheath horizontally hung	<i>Seaxes with blades up to 13"</i> Bone handles	Worked antler handles Undecorated knife sheath Composite wood / bone / stone handles [RICH]	Double edged knives Un-sheathed knives Unworked antler handles Wooden handles with bark
<b>Sword</b>		C8th-9th sword types Single Edge Sword [V] Swords on baldrics Langseaxes [E][RICH] Composite wooden / leather plain scabbard	Swords on sword belts Leather scabbard	Disc pommels & C10-11th sword types Un-scabbarded swords Painted scabbards Elaborately decorated scabbards
<b>Other</b>	All hand axe types [V] <i>Axes hafted with wooden wedges</i>	All hand axe types [E]	Leather axe loops Edge protector for axe	Francisca Broadaxe (Dane axe) Metal axe rings Maces
<b>Missile</b>		Self-bow with arrows in quiver Javelins	Re-curve Self-bow Slings	Crossbows Bodkin heads

[R] = Restricted; [E] = English; [V] = Viking; [RICH] = Thegn / Odalsbondi / Hauldr ; [POOR] = Bonded / Serf / Slave

Regia Anglorum  
900-979AD



English Costume



Viking Jewellery



English Jewellery

Dublin Scarf

Viking Cap



Hangerock Set

Viking Costume

**Women's Clothing - Early (900–979AD)**

	<b>Encouraged (Very Common)</b>	<b>Optional (Less Common)</b>	<b>Allowable (Interpreted or Rare)</b>	<b>Unacceptable</b>
<b>Head</b>	Veils over a cap, headscarf or wide headband and that shows the throat [E] Dublin scarf with hair showing in an authentic style [V] Cap with hair showing [V]	Wimple over a cap, headscarf or wide headband [E] Bareheaded long hair (past shoulder) [V] Bead necklace [V]	Headscarves [POOR] Hoods [POOR] Palla [E] Veils with long tails [RICH] [E] Sprang hair net [V]	Bareheaded women / teenage girls [E] Obviously dyed hair Makeup Any tie or fillet worn over the head covering
<b>Under Shift</b>	Shift made from linen with a bias edged keyhole or oval neck hole Natural linen	Tight sleeves with rucking [E] Pleated shift [V] Small brooch at throat [V] Dyed a light colour or bleached	Different colour square or round facing Dyed a strong colour Embroidery [RICH] Short visible shift, just above the ankle [POOR]	Other decoration Visible shift above mid-calf Brooch at the throat [E]
<b>Dress</b>	Woollen ankle length dress with keyhole or oval neck hole Tight or loose sleeves Embroidery [E][RICH] Wool or linen hangerock to mid shin (must be worn with oval brooches) [V]	Dress sleeves to mid forearm [E] Dress to mid shin (must be worn with ankle length shift) [E] Beads between oval brooches [V] Decorated with: - Decorative seams - Braid - Tablet weave (1 to 3 colours) - Brocaded tablet weave [RICH] - Embroidery [E] [RICH] - Silk ribbons [RICH]	Dress made from linen Decorated hem with an embroidered facing or braid [RICH] <i>'Decorative' brooch [RICH]</i> <i>Dress to mid forearm and mid shin with no visible under shift [POOR] [R]</i>	Norman style dress Dress above mid-shin Different coloured gores or sleeves Other decoration including chunky wool
<b>Belt &amp; Bags</b>	No belts or girdles	Braided textile belt Cloth sash in same material as garment worn with - dress or mantle [E] Leather or cloth satchels or sacks <i>Drawstring pouch</i> <i>Small knife in sheath [V]</i>	Woven textile girdle Hidden leather tie belt Small drawstring or tagged pouches Forged snips in sheath <i>Small knife in sheath [E]</i>	Chunky wool girdle Leather belts with buckles Box pouch Modern snips or scissors
<b>Cloak</b>	Cloaks clasped at the chest with disc brooch Pinned with ringed pin, penannular or trefoil [V]	Mantles [E] Edged with different coloured facing Backtrain suspended from oval brooches [V]	Hooded cloaks Long jackets (With brooch) [V] Cloak pinned with pin or penannular	Cloaks pinned at hip Different coloured lining
<b>Leg</b>	Bare legs		Trousers or hose if hidden Leg bindings	
<b>Shoes</b>	Low shoes or ankle boots (to bottom of ankle bone) Bare feet	Nålebound socks [V]	Ankle boots (up to top of ankle bone) [V] Nålebound socks [E] Foot wraps or sock bags Footed hose or half hose	Tall boots (higher than top of ankle bone) 12 <sup>th</sup> C. or later patterns 8 <sup>th</sup> C. or earlier patterns

[R]= Restricted; [E]= English; [V]= Viking; [N]= Norman; [RICH]= Thegn / Odalsbondi / Hauldr ; [POOR]= Bonded / Serf / Slave



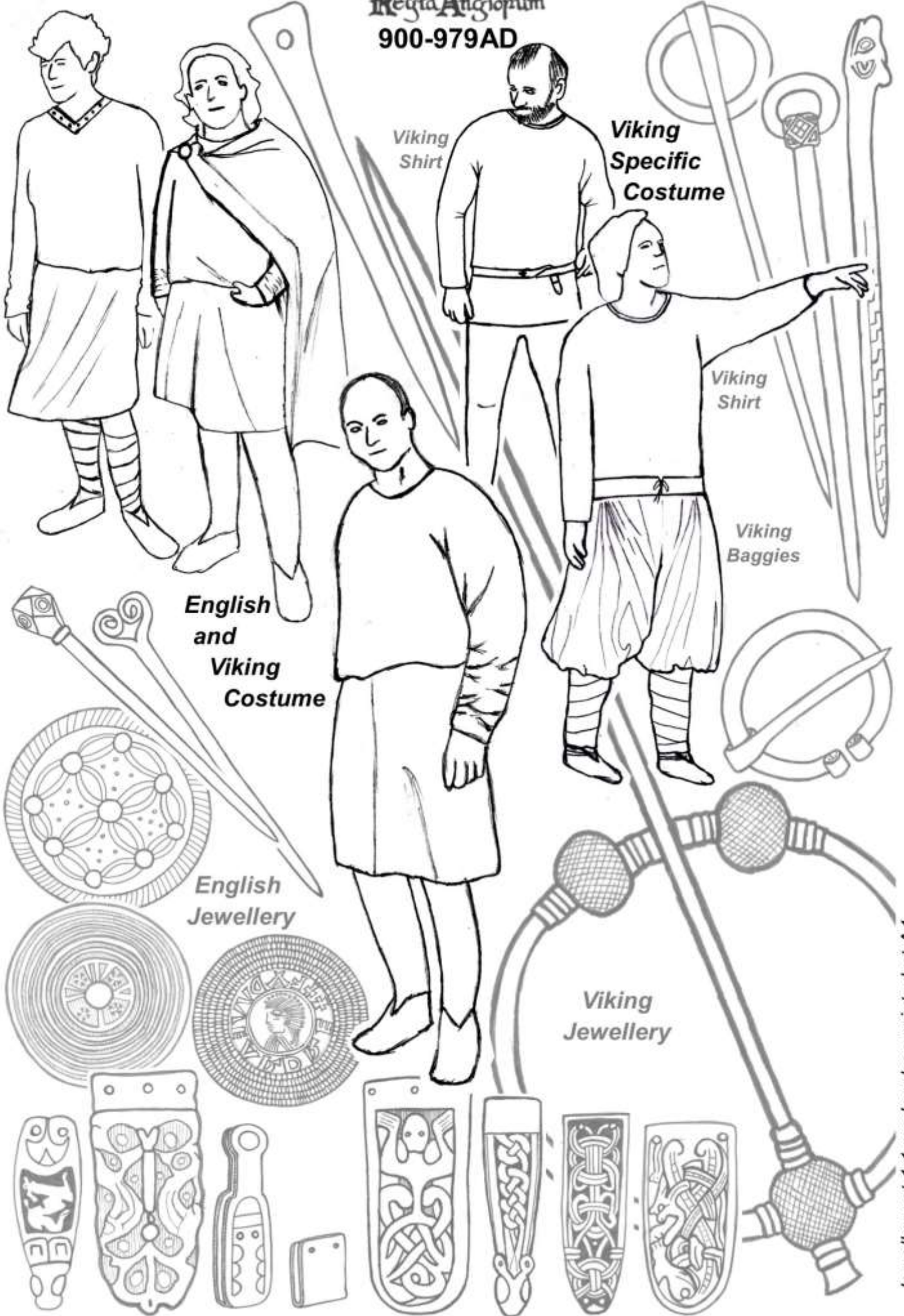

**Men's Clothing - Early (900–979AD)**

	<b>Encouraged (Very Common)</b>	<b>Optional (Less Common)</b>	<b>Allowable (Interpreted or Rare)</b>	<b>Unacceptable</b>
<b>Head</b>	Bare headedness	Wool hoods	Linen or leather hoods Skull caps Straw hats [POOR][R] Necklace with 2 beads Frisian caps [R] Birka style hats with fittings [V][R]	Cloth "Phrygian caps" Obviously dyed hair Bead necklaces Nålebound caps [R] Fur caps
<b>Under Shirt</b>	Natural or bleached shirt made from linen with a bias edged keyhole or oval neck hole Side split	Shirt as outer garment with hem ending up to 2" above the knee Shirt made from wool Dyed a light colour Shirts with skirt gores Square neck holes	<i>Shirt as outer garment tucked into trousers [V]</i> <i>Short shirt as outer garment [V]</i> Different colour round or square facing Dyed a strong colour Embroidery [RICH]	Shirts visible below tunic Front split Other decoration
<b>Tunic</b>	Tunics made of wool Rucked up to knee length with tight rucked sleeves [E] Shorter tunics un-rucked to knee length with tight sleeves and no rucking [V] Keyhole or oval neck hole with bias edging	Tunics made of linen Neck hole closed with ties Decorated with: - Decorative seams - Braid - Tablet weave (1 to 3 colours) - Brocaded tablet weave [RICH] - Embroidery [E] [RICH] - Silk ribbons [RICH] <i>Rucked tunics with hems that end up to 2" above the knee</i>	<i>Shorter tunics un-rucked to mid-thigh [V]</i> Tunics with faced round or square keyhole style neck hole Tunic closed with authentic hook & eye Side split [R]	Front split Loose sleeves Shorter than 2" above knee level when unbelted Brooch worn at throat Different coloured gores or sleeves Decorated with: - Chunky wool - braid/facing around hem
<b>Belt &amp; Bags</b>	Buckled leather belt or cloth tie hidden by tunic [E] Small knife in sheath	Visible buckled leather belts or cloth tie [V] Leather or cloth satchels or sacks <i>Drawstring pouch</i>	Visible buckled leather belts or cloth ties [E] Split end leather belts Belts with metal plates [V] Birka style pouches [V][R] Drawstring or tagged pouches worn on belt	Belts knotted around the buckle Long hanging belt end Chunky wool belt Box pouches
<b>Cloak</b>	Rectangular cloaks pinned at shoulder with disc brooch [E] Hanging length from waist to knee	Pinned with metal or bone pin or metal penannular [V] Edged with different coloured facing Wrap around jackets [R][V] Cloaks with tassels	Cloaks pinned at front Fur or piled wool lining Long buttoned jacket [R][V] Pinned with penannular Cloak ribbons [V][RICH] Different coloured linings [RICH][R] Hooded mantle [POOR][R]	Mantles Different coloured lining Leather or fur cloaks
<b>Legs</b>	Wool trousers or hose tight to legs with leg bindings Trousers or hose with integral feet Bare legs [POOR]	Wool trousers or hose tight to legs with no leg bindings Loose legged trousers or baggy trousers to knee [V]	Linen trousers or hose Tight leather hose worn with spurs [RICH] Elaborate ties or leather garter below knee [RICH] Non-visible Braies worn on their own	Loose legged trousers [E] Cross gartering Baggy trousers tied at the ankle
<b>Shoes</b>	Low shoes or ankle boots (to bottom of ankle bone) Bare feet	Nålebound socks [V]	Nålebound socks [E] Carolingian 3 toggled tall boot [V] Foot wraps or sock bags	Tall boots (higher than top of ankle bone) 12 <sup>th</sup> C. or later patterns 8 <sup>th</sup> C. or earlier patterns

[R]= Restricted; [E]= English; [V]= Viking; [N]= Norman; [RICH]= Thegn / Odalsbondi / Hauldr ; [POOR]= Bonded / Serf / Slave



Regia Anglorum  
900-979AD

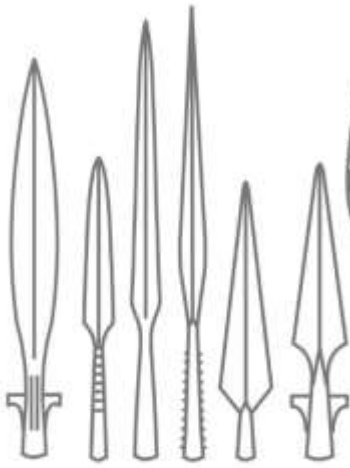

Viking Weapons

English Weapons



**Wargear - Early (900–979AD)**

	<b>Encouraged (Very Common)</b>	<b>Optional (Less Common)</b>	<b>Allowable (Interpreted or Rare)</b>	<b>Unacceptable</b>
<b>Helm</b>		Coppergate helms [E] Spectacle helms [V] Domed helm – riveted Helms with aventails Helms without nasals	Conical helm – riveted panels Hardened leather caps	Vendel / Valsgarde helm Boar crested helms Great Polish helm Conical helm – ‘single piece’
<b>Armour</b>		<i>Mail shirt length from below groin to knee [RICH]</i> Unsplit or side split 6 - 8mm alternating riveted & welded 6 - 8mm riveted	Vandyked mail shirt Leather jack, leather or cloth padded gambeson worn under mail Leather jack or leather padded gambeson worn as armour <i>Cloth padded gambeson worn as armour [R]</i> Butted / riveted links up to 10mm <i>Simple leather gloves</i>	Mail shirt with integral coif Separate coif Front split mail shirt Splinted arms or legs Lamellar / Scale Cuir Bouilli / Plate <i>Mail covered gloves</i>
<b>Shield</b>	<i>Large round shields that extend past the elbow by 2" or more</i> Flat round shield [V] Lenticular round shield [E] Sewn on leather or rawhide edge Painted in a single colour	Smaller shields that don't cover the elbow Flat round shields [E] Nailed on leather or rawhide edge Painted in a cross [E] or radiating curved lines [V] Painted in up to 3 colours	Painted in Oseberg, Borre, Jellinge [V] [RICH] Painted in Trewiddle or Winchester art style [E][RICH] Painted in other simple geometric design Painted in 4 or more colours [R]	Kite shields Unbossed shield Rectangular or oval shields Painted in Celtic knotwork Painted in other art style or design
<b>Spear</b>	1-handed spears Angular shaped heads	<i>2-handed winged spears with blade of 8" – 16" [after 1/1/2017]</i> Leaf shaped heads	<i>2-handed spears with blade of 8" – 16" [after 1/1/2017]</i>	Angon
<b>Knife</b>	<i>Seaxes with blades from 7" to 10"</i> Wood Handles Decorated knife sheath horizontally hung	Bone handles	<i>Seaxes with blades up to 12" [until 1/1/2017]</i> Worked antler handles Undecorated knife sheath Composite wood / bone / stone handles [RICH]	Double edged knives Un-sheathed knives Unworked antler handles Wooden handles with bark
<b>Sword</b>		C9th-10th sword types Single edge sword [V] Swords on baldrics Langseaxes [E][RICH] Composite wooden / leather plain scabbard	Swords on sword belts Leather scabbard	Disc pommels & C11th sword types Un-scabbarded swords Painted scabbards Elaborately decorated scabbards
<b>Other</b>	All hand axe types [V] <i>Axes hafted with wooden wedges</i>	All hand axe types [E]	Leather axe loops Edge protector for axe	Francisca Broadaxe (Dane axe) Metal axe rings Maces
<b>Missile</b>		Self-bow with arrows in quiver Javelins	Re-curve Self-bow Slings	Crossbows Bodkin heads

[R]= Restricted; [E]= English; [V]= Viking; [N]= Norman; [RICH]= Thegn / Odalsbondi / Hauldr ; [POOR]= Bonded / Serf / Slave

Regia Anglorum  
980-1041AD



Decorative brooches

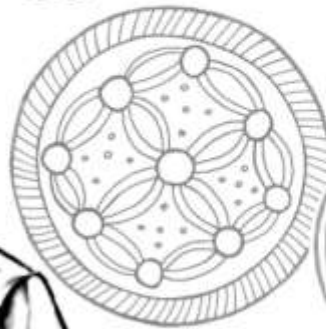

Fastening Brooches



**Women's Clothing - Mid (980–1041AD)**

	<b>Encouraged (Very Common)</b>	<b>Optional (Less Common)</b>	<b>Allowable (Interpreted or Rare)</b>	<b>Unacceptable</b>
<b>Head</b>	Veil or wimple over a cap, headscarf or wide headband and that shows the throat	Veils worn over decorative headbands [RICH]	Headscarves [POOR] Hoods [POOR] Veils with long tails [RICH]	Bareheaded women / teenage girls Obviously dyed hair Makeup Any tie or fillet worn over the head covering Bead necklace Palla
<b>Under Shift</b>	Shift made from linen, ankle length with a bias edged keyhole or oval neck hole Natural linen Tight sleeves with rucking	Dyed a light colour or bleached Embroidery [RICH]	Different colour square or round facing Dyed a strong colour Short visible shift, just above the ankle [POOR]	Other decoration Visible shift above mid-calf Pleated underdress Brooch worn at throat
<b>Dress</b>	Woollen ankle length dress with keyhole or oval neck hole and loose sleeves to mid forearm Embroidery [RICH]	Dress to mid shin (must be worn with ankle length shift) Decorated with: - Decorative seams - Braid - Tablet weave (1 to 3 colours) - Brocaded tablet weave [RICH] - Embroidery [RICH] - Silk ribbons [RICH]	Tight sleeves Dress made from linen Decorated hem with an embroidered facing or braid [RICH] <i>'Decorative' brooch [RICH]</i> <i>Dress to mid forearm and mid shin with no visible under shift [POOR] [R]</i>	Norman style dress Dress above mid-shin Different coloured gores or sleeves Other decoration including chunky wool Hangerock or oval brooches
<b>Belt &amp; Bags</b>	No belts or girdles	Cloth sash in same material as garment worn with - dress or mantle Leather or cloth satchels or sacks <i>Drawstring pouch</i>	Braided or woven textile girdle (no dangling ends) Hidden leather tie belt Small drawstring or tagged pouches Forged snips in sheath <i>Small knife in sheath</i>	Chunky wool girdle Leather belts with buckles Box pouch Modern snips or scissors
<b>Cloak</b>	Mantles	Cloaks clasped at the chest with disc brooch	Cloak pinned with a pin or penannular	Trefoil brooches Equal armed brooches Backtrains Different coloured lining
<b>Legs</b>	Bare legs		Trousers or hose if hidden Leg bindings	
<b>Shoes</b>	Low shoes or ankle boots (to bottom of ankle bone) Bare feet		Nålebound socks Ankle boots (up to top of ankle bone) Foot wraps or sock bags Footed hose or half hose	Tall boots (higher than top of ankle bone) 12 <sup>th</sup> C. or later patterns 8 <sup>th</sup> C. or earlier patterns

[R] = Restricted; [RICH] = Thegn / Odalsbondi / Hauldr ; [POOR] = Bonded / Serf / Slave



Regia Anglorum  
980-1041AD

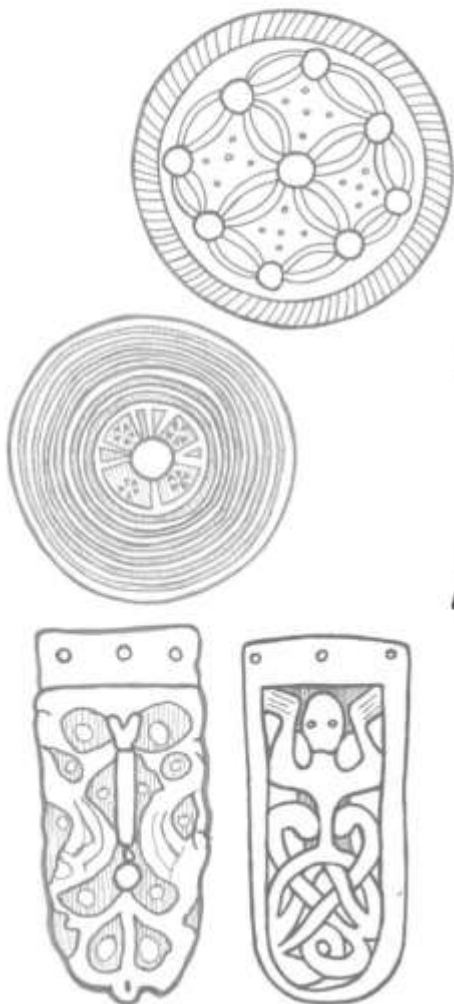

**Men's Clothing - Mid (980–1041AD)**

	<b>Encouraged (Very Common)</b>	<b>Optional (Less Common)</b>	<b>Allowable (Interpreted or Rare)</b>	<b>Unacceptable</b>
<b>Head</b>	Bare headedness	Wool hoods	Linen or leather hoods Skull caps Straw hats [POOR][R] Necklace with 2 beads Pointed hats [E] [RICH]	Cloth "Phrygian caps" Obviously dyed hair Bead necklaces Frisian caps Nålebound caps [R] Fur caps
<b>Under Shirt</b>	Natural or bleached shirt made from linen with a bias edged keyhole or oval neck hole Side split	Shirt as outer garment <i>with hem ending up to 2" above the knee</i> Shirt made from wool Dyed a light colour Shirts with skirt gores	Different colour round or square facing Dyed a strong colour Embroidery [RICH]	Shirts visible below tunic Front split Other decoration
<b>Tunic</b>	Tunics made of wool Rucked up to knee length with tight rucked sleeves Keyhole or oval neck hole with bias edging Tunics with faced square keyhole style neck hole	Tunics made of linen Tunics with faced round keyhole style neck hole Neck hole closed with ties Decorated with: - Decorative seams - Braid - Tablet weave (1 to 3 colours) - Brocaded tablet weave [RICH] - Embroidery [RICH] - Silk ribbons [RICH] <i>Rucked tunics with hems that end up to 2" above the knee</i> <i>Simple embroidery around the skirt (but not around the hem)</i>	Tight sleeves with no rucking Tunic closed with authentic hook & eye Side split [R]	Loose sleeves Different coloured gores or sleeves Shorter than 2" above knee level when unbelted Front splits Brooch worn at throat Decorated with: - Chunky wool - facing, braid or embroidery around the hem
<b>Belt &amp; Bags</b>	Buckled leather belt or cloth tie hidden by tunic Small knife in sheath	Visible buckled leather belts or cloth tie [V] Leather or cloth satchels or sacks <i>Drawstring pouch</i>	Visible leather belt or cloth tie [E] Split end leather belts Belts with metal plates [V] Drawstring or tagged pouches worn on belt	Belts knotted around the buckle Long hanging belt end Chunky wool belt Box pouch
<b>Cloak</b>	Rectangular cloaks pinned at shoulder with disc brooch [E] Hanging length from waist to knee	Pinned with metal or bone pin Cloak ribbons [RICH] Edged with different coloured facing Cloaks with tassels	Cloaks pinned at chest Fur or piled wool lining Pinned with penannular Different coloured linings [RICH][R] Hooded mantle [POOR][R]	Viking jackets Mantles Cloaks pinned at hip Different coloured lining Leather or fur cloaks
<b>Legs</b>	Wool trousers or hose tight to legs with leg bindings Trousers or hose with integral feet Bare legs [POOR]	Wool trousers or hose tight to legs with no leg bindings	Linen trousers or hose Tight leather hose worn with spurs [RICH] Elaborate ties or leather garter below knee [RICH] Non-visible Braies worn on their own	Viking baggy trousers Loose legged trousers Cross gartering
<b>Shoes</b>	Low shoes or ankle boots (to bottom of ankle bone) Bare feet		Ankle boots (up to top of ankle bone) Nålebound socks Foot wraps or sock bags	Tall boots (higher than top of ankle bone) 12 <sup>th</sup> C. or later patterns 8 <sup>th</sup> C. or earlier patterns

[R]= Restricted; [E]= English; [V]= Viking; [N]= Norman; [RICH]= Thegn / Odalsbondi / Hauldr ; [POOR]= Bonded / Serf / Slave

Regia Anglorum  
980-1041AD

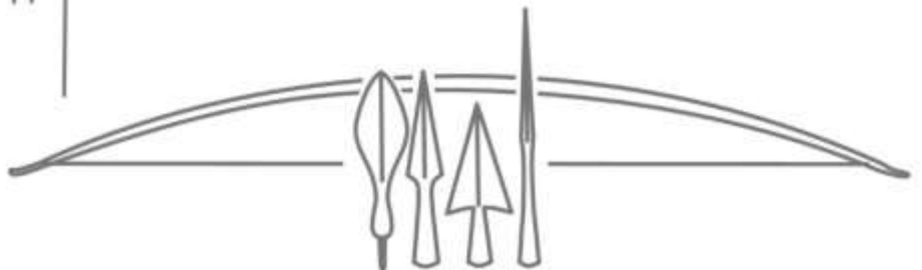
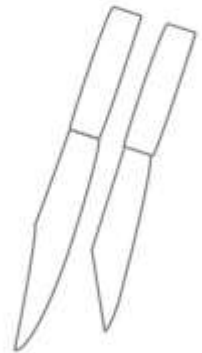
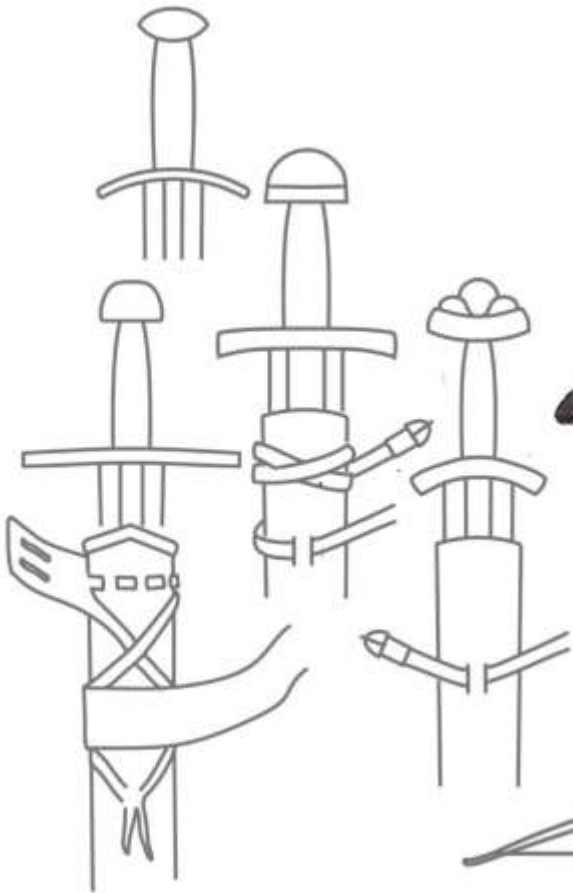
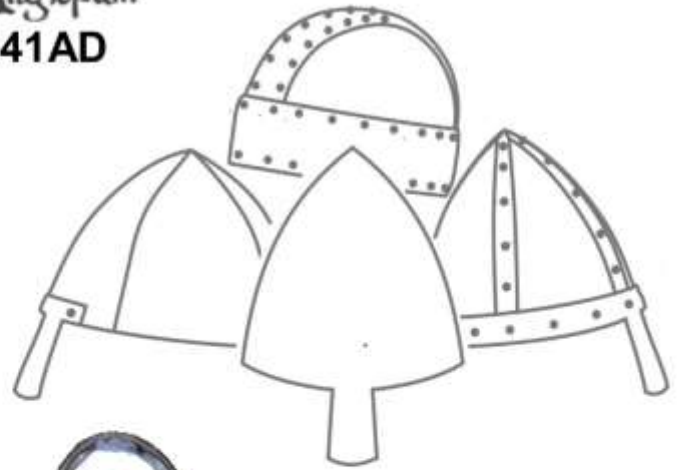

**Wargear - Mid (980–1041AD)**

	<b>Encouraged (Very Common)</b>	<b>Optional (Less Common)</b>	<b>Allowable (Interpreted or Rare)</b>	<b>Unacceptable</b>
<b>Helm</b>	Conical helm – riveted panels / welded panels or 'single piece' Helms with aventails	Domed helm – riveted Helms without nasals	Great Polish helm [V] [R] Hardened leather cap	Boar crested helm Coppergate helm Spectacle helm
<b>Armour</b>	Mail shirt length from below groin to knee Unsplit or side split 6 - 8mm alternating riveted & welded	6 - 8mm riveted <i>Leather jack, leather or cloth padded gambeson worn under mail</i>	Leather jack or leather padded gambeson worn as armour <i>Cloth padded gambeson worn as armour [R]</i> Butted / riveted links up to 10mm <i>Simple leather gloves</i>	Mail shirt with integral coif Separate coif Front split mail shirt Vandyked mail shirt Splinted arms or legs Lamellar / Scale Cuir Boilli / Plate Full length mailed sleeves <i>Mail covered gloves</i>
<b>Shield</b>	<i>Large round shields that extend past the elbow by 2" or more</i> Flat round shield [V] Lenticular round shield [E] Sewn on leather or rawhide edge Painted in a single colour	Smaller shields that don't cover the elbow Flat round shields [E] Nailed on leather or rawhide edge Painted in a cross [E] or radiating curved lines [V] Painted in up to 3 colours	Painted in Ringerike, Mammen or Winchester art styles [RICH] Painted in other simple geometric design Painted in 4 or more colours [R]	Kite shield Unbossed shield Rectangular or oval shields Painted in Celtic knotwork Painted in other art style or design
<b>Spear</b>	1-handed spear Angular shaped heads	<i>2-handed winged spears with blade of 8" – 16" [after 1/1/2017]</i>	<i>2-handed spears with blade of 8" – 16" [after 1/1/2017]</i> Leaf shaped heads	Angon
<b>Knife</b>	<i>Seaxes with blades from 7" to 10"</i> Wood handles Decorated knife sheath horizontally hung	Bone Handles	<i>Seaxes with blades up to 12" [until 1/1/2017]</i> Worked antler handles Undecorated sheath Composite wood / bone / stone handles [RICH]	Double edged knives Un-sheathed knives Unworked antler handles Wooden handles with bark
<b>Sword</b>	Late 10 <sup>th</sup> or early C11th sword types Swords on baldrics Composite wooden / leather plain scabbard	Early C10th sword types Swords on sword belts	Langseax [E][RICH] Leather scabbard	Disc pommels C9 <sup>th</sup> sword types Unscabbarded swords Single edge swords Painted scabbards Elaborately decorated scabbards
<b>Other</b>	Broadaxe (Dane axe) [V] [E, post 1016AD] <i>Axes hafted with wooden wedges</i>	Hand axes without beards	Hand axes with beards Leather axe loops Edge protector for axe	Francisca Metal axe rings Maces
<b>Missile</b>		Self-bow with arrows in quiver Bodkin heads Javelins	Re-curve Self-bow Slings	Crossbows

[R]= Restricted; [E]= English; [V]= Viking; [N]= Norman; [RICH]= Thegn / Odalsbondi / Hauldr ; [POOR]= Bonded / Serf / Slave

Regia Anglorum  
1042-1079AD



European style veil



Norman style



Decorative brooches

Bliaut square style

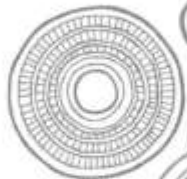

Fastening Brooches

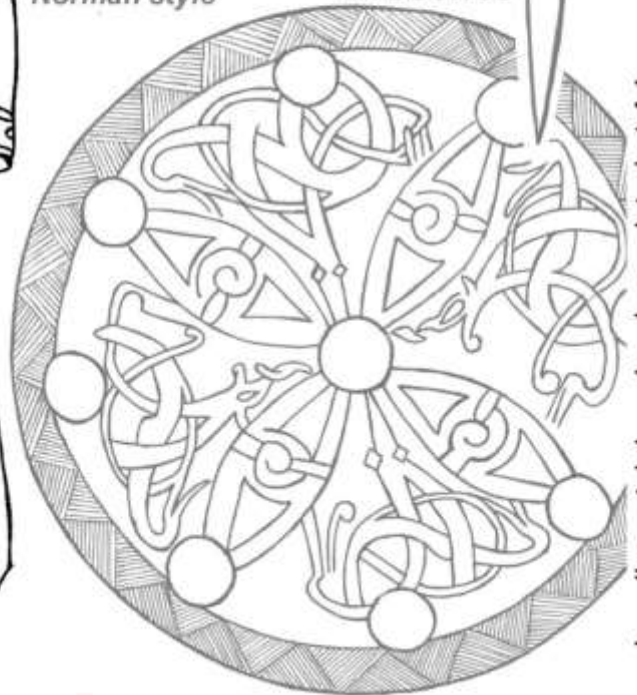



**Women's Clothing - Late (1042–1079AD)**

	<b>Encouraged (Very Common)</b>	<b>Optional (Less Common)</b>	<b>Allowable (Interpreted or Rare)</b>	<b>Unacceptable</b>
<b>Head</b>	Veil or wimple over a cap, headscarf or wide headband and that shows the throat	Decorated headband worn under veil or wimple [RICH]	Headscarves [POOR] Hoods [POOR] Veils with long tails [RICH]	Bareheaded women / teenage girls Obviously dyed hair Makeup Any tie or fillet worn over the head covering Bead necklace Palla
<b>Under Shift</b>	Shift made from linen, ankle length with a bias edged keyhole or oval neck hole Natural linen Tight sleeves with rucking	Dyed a light colour or bleached Embroidery [RICH]	Different colour square or round facing Dyed a strong colour Short visible shift, just above the ankle [POOR]	Other decoration Visible shift above mid-calf Pleated underdress Broach worn at throat
<b>Dress</b>	Woollen ankle length dress with keyhole or oval neck hole and loose sleeves to mid forearm Embroidery [RICH]	Norman style dress with droopy sleeves to mid forearm [N] [RICH] Decorated with: - Braid - Tablet weave (1 to 3 colours) - Brocaded tablet weave [RICH] - Embroidery [RICH] - Silk ribbons [RICH]	Cinching at sides [N] Overdress to mid shin (must be worn with ankle length shift) Tight sleeves Dress made from linen <i>Decorated hem with a facing, embroidered facing or braid</i> <i>'Decorative' brooch [RICH]</i> <i>Dress to mid forearm and mid shin with no visible under shift [POOR] [R]</i>	Dress above mid-shin Different coloured gores or sleeves Other decoration including chunky wool Hangerocks or oval brooches
<b>Belt &amp; Bags</b>	No belts or girdles	Cloth sash in same material as garment worn with - dress or mantle Leather or cloth satchels or sacks <i>Drawstring pouch</i>	Braided or woven textile girdle (no dangling ends) Hidden leather tie belt Small drawstring or tagged pouches Forged snips in sheath <i>Small knife in sheath</i>	Chunky wool girdle Leather belts with buckles Box pouch Modern snips or scissors
<b>Cloak</b>	Mantles worn with a matching cloth sash	Cloaks clasped at the chest with disc brooch	Cloak pinned with pin or penannular	Trefoil brooches Equal armed brooches Backtrains Different coloured lining
<b>Legs</b>	Bare legs		Trousers or hose if hidden Leg bindings	
<b>Shoes</b>	Low shoes or ankle boots (to bottom of ankle bone) Bare feet		Nålebound socks Ankle boots (up to top of ankle bone) Foot wraps or sock bags Footed hose or half hose	Tall boots (higher than top of ankle bone) 8 <sup>th</sup> C. or earlier patterns

[R] = Restricted; [N] = Norman; [RICH] = Thegn / Odalsbondi / Hauldr ; [POOR] = Bonded / Serf / Slave

Regia Anglorum  
1042-1079AD



Norman  
front-split  
shirt

European  
style



Norman  
style



**Men's Clothing - Late (1042–1079AD)**

	<b>Encouraged (Very Common)</b>	<b>Optional (Less Common)</b>	<b>Allowable (Interpreted or Rare)</b>	<b>Unacceptable</b>
<b>Head</b>	Bare headedness	Woollen hoods	Linen or leather hoods Skull caps Straw hats [POOR][R] Pointed hats [RICH]	Cloth "Phrygian caps" Obviously dyed hair Bead necklaces Frisian caps Nålebound caps [R] Fur caps
<b>Under Shirt</b>	Natural or bleached shirt made from linen with a bias edged keyhole or oval neck hole Side split	Shirt as outer garment <i>with hem ending up to 2" above the knee</i> Shirt made from wool Dyed a light colour Shirts with skirt gores Front split [N]	Different colour round or square facing Dyed a strong colour Embroidery [RICH]	Shirts visible below tunic Other decoration
<b>Tunic</b>	Tunics made of wool Rucked up to knee length with tight rucked sleeves Tunics with faced oval keyhole style neck hole Keyhole or oval neck hole with bias edging Neck hole closed with ties	Tunics made of linen Tunics with faced square keyhole style neck hole Decorated with: - Braid - Tablet weave (1 to 3 colours) - Brocaded tablet weave [RICH] - Embroidery [RICH] - Silk ribbons [RICH] Facing and decoration around the hem <i>Simple embroidery around the skirt</i> <i>Rucked tunics with hems that end up to 2" above the knee</i>	Shorter tunics un-rucked to knee length [N] Tight sleeves with no rucking Tunic closed with authentic hook & eye Front split [R] Side split	Loose sleeves Different coloured gores or sleeves Shorter than 2" above knee level when unbelted Brooch worn at throat Decorated with chunky wool
<b>Belt &amp; Bags</b>	Buckled leather belts or cloth ties hidden by tunic Small knife in sheath	Split end belts Visible leather belt or cloth tie Leather or cloth satchels or sacks <i>Drawstring pouch</i>	Drawstring or tagged pouches worn on belt	Belts knotted around the buckle Long hanging belt end Belts with metal plates Chunky wool belt Box pouch
<b>Cloak</b>	Rectangular cloaks pinned at shoulder with disc brooch Hanging length from waist to knee	Pinned with metal or bone pin Cloak ribbons [RICH] Edged with different coloured facing	Cloaks pinned at chest Fur or piled wool lining Cloaks with tassels Pinned with penannular Different coloured linings [RICH][R] Circular style cloaks Hooded mantle [POOR][R]	Viking jackets Mantles Cloaks pinned at hip Different coloured lining Leather or fur cloaks
<b>Legs</b>	Wool trousers or hose tight to legs with leg bindings Trousers or hose with integral feet Bare legs [POOR]	Wool trousers or hose tight to legs with no leg bindings	Linen trousers or hose Tight leather hose worn with spurs [RICH] Cross gartering [N] Elaborate ties below knee [RICH] Non-visible Braies worn on their own	Viking baggy trousers Loose legged trousers
<b>Shoes</b>	Low shoes or ankle boots (to bottom of ankle bone) Bare feet	Ankle boots (up to top of ankle bone)	Norman style laced tall boots [N] Nålebound socks Foot wraps or sock bags	Other boot styles 8 <sup>th</sup> C. or earlier patterns

[R]= Restricted; [E]= English; [V]= Viking; [N]= Norman; [RICH]= Thegn / Odalsbondi / Hauldr ; [POOR]= Bonded / Serf / Slave

Regia Anglorum  
1042-1079AD

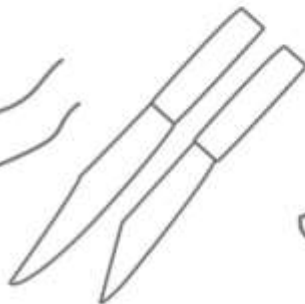
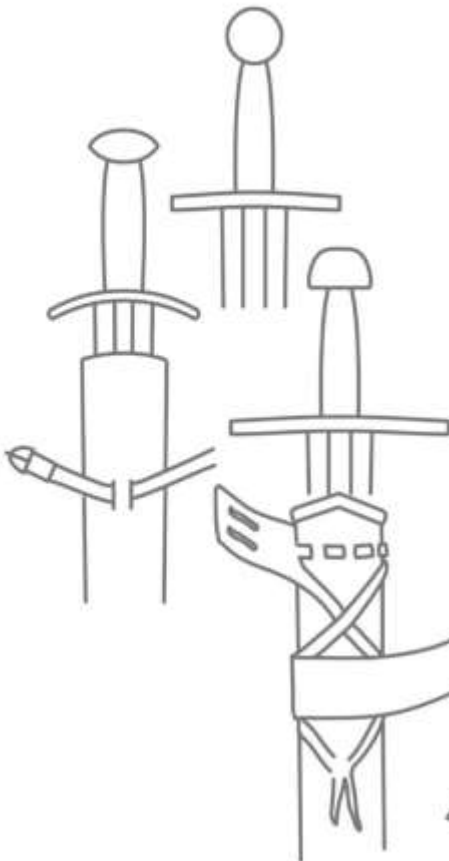
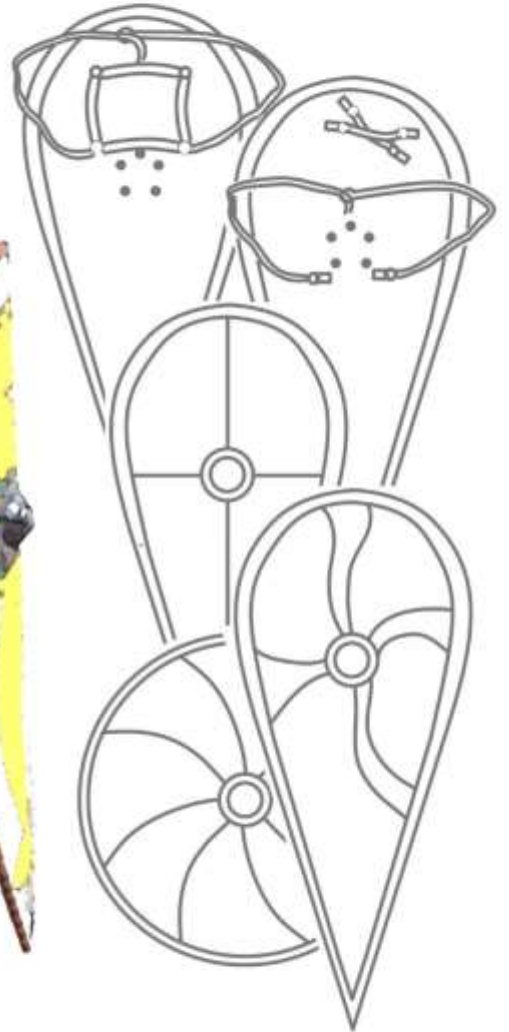
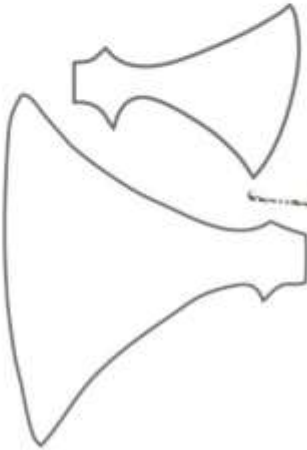

**Wargear - Late (1042–1079AD)**

	<b>Encouraged (Very Common)</b>	<b>Optional (Less Common)</b>	<b>Allowable (Interpreted or Rare)</b>	<b>Unacceptable</b>
<b>Helm</b>	Conical helm – riveted panels / welded panels or 'single piece'	Helms with aventails Helms without nasals	Domed helm – riveted Great Polish helm [V] [R] Hardened leather cap	Spectacle helms Boar crested helms Coppergate helms Faceplated / kettle helms
<b>Armour</b>	Mail shirt length from below groin to knee Mail shirt with integral coif and chest square ventail Front/back split mail shirt Leather jack, leather or cloth padded gambeson worn under mail 6 - 8mm alternating riveted & welded	Unsplit mail shirt Leather jack or leather padded gambeson worn as armour 6 – 8mm riveted	Separate coifs (should be disguised) Side split mail shirt Mailed arm/leg protection -or- long sleeves & hood [RICH, post 1066AD] <i>Cloth padded gambeson worn as armour [R]</i> Butted / riveted links up to 10mm <i>Simple leather gloves</i>	Vandyked mail shirt Splinted arms or legs Lamellar / Scale Cuir Boilli / Plate armour <i>Integral mail covered mittens</i> <i>Separate mail covered gloves</i>
<b>Shield</b>	Kite shield with boss <i>Large round shields that extend past the elbow by 2" or more</i> Lenticular round shield Sewn on leather or rawhide edge Painted in a single colour	Smaller shields that don't cover the elbow Flat round shield Nailed on leather or rawhide edge Kite shield painted with zoomorphic design [N][RICH] Painted in a cross or simple design Painted in up to 3 colours	Round or lenticular shields painted in Ringerike, Urnes [E][V][RICH] Painted in other simple geometric design Painted in 4 or more colours [R]	Flat topped kite Unbossed shield Rectangular or oval shields Painted in other art style or design
<b>Spear</b>	1-handed spear Angular shaped heads		<i>2-handed spears or winged spears with blade of 8" – 16" [after 1/1/2017]</i> Leaf shaped heads	Angon
<b>Knife</b>	<i>Seaxes with blades from 7" to 10"</i> Wood handles	Bone handles Decorated knife sheath horizontally hung	<i>Seaxes with blades up to 12" [until 1/1/2017]</i> Worked antler handles Undecorated sheath Composite wood / bone / stone handles [RICH]	Double edged knives Un-sheathed knives Norse style blades Unworked antler handles Wooden handles with bark
<b>Sword</b>	Brazil, disc & tea cosy pommels on swords Swords on sword belts Composite wooden / leather plain scabbard	Swords on baldrics Other C11th sword types	C10 <sup>th</sup> sword types	Unscabbarded weapons C8th & C9th sword types Single edged swords Langseax Decorated scabbards
<b>Other</b>	Broadaxes (Dane axe) <i>Axes hafted with wooden wedges</i>	Hand axes without beards	Hand axes with beards Leather axe loops Edge protector for axe Mace [RICH] [R]	Francisca Metal axe rings Flanged mace
<b>Missile</b>	Self-bow with arrows in quivers Bodkin heads Javelins		Re-curve Self-bow Crossbows (locking nut) [N] Slings	

[R]= Restricted; [E]= English; [V]= Viking; [N]= Norman; [RICH]= Thegn / Odalsbondi / Hauldr ; [POOR]= Bonded / Serf / Slave



Regia Anglorum  
1080-1179AD



Norman  
style  
dress



Decorative  
brooches



Fastening  
Brooches



Bliaut  
square  
style

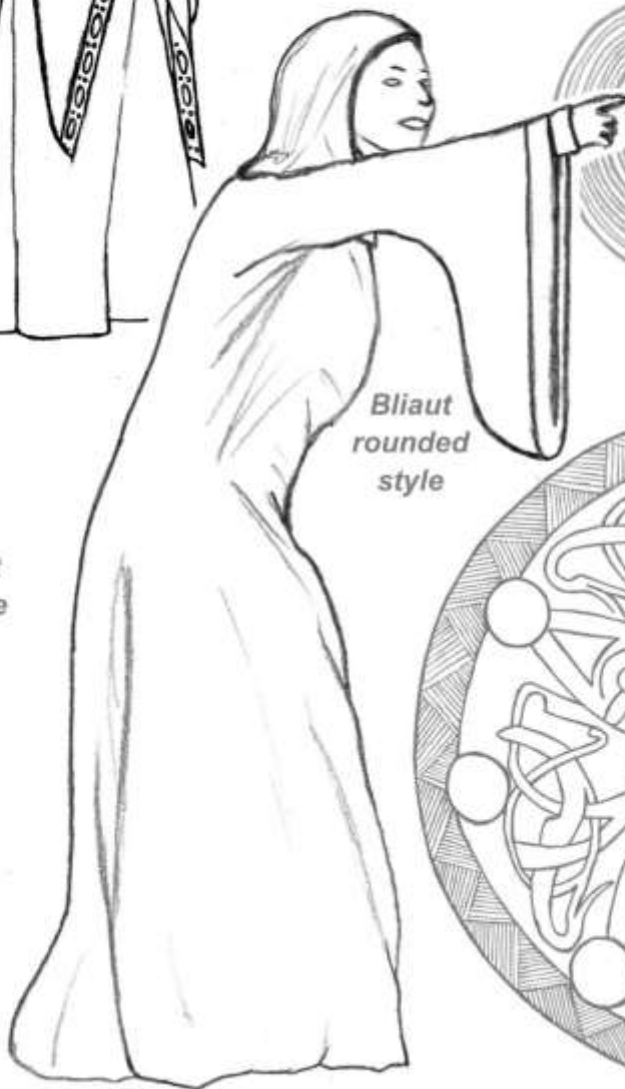

Bliaut  
rounded  
style

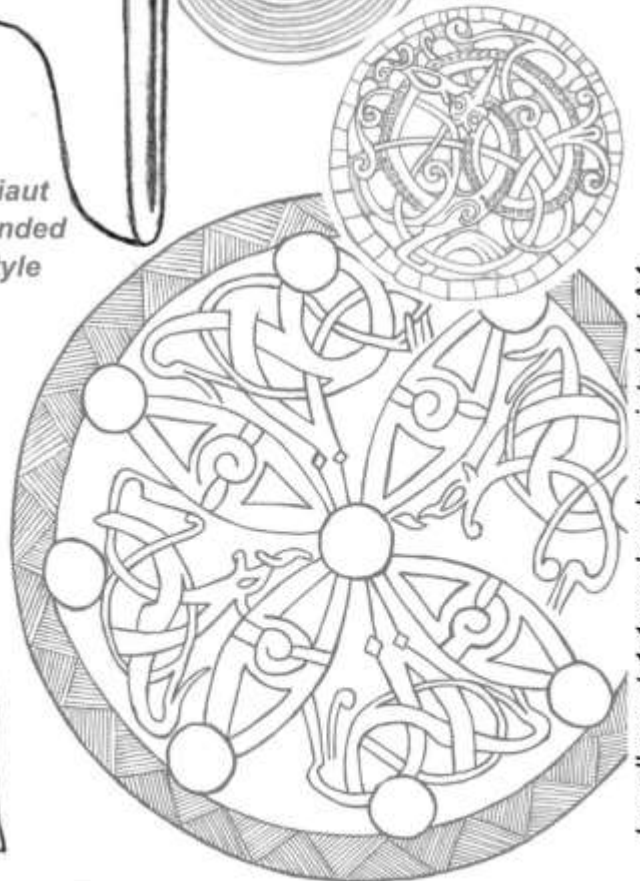

**Women's Clothing – Very Late (1080–1179AD)**

	<b>Encouraged (Very Common)</b>	<b>Optional (Less Common)</b>	<b>Allowable (Interpreted or Rare)</b>	<b>Unacceptable</b>
<b>Head</b>	Veil or wimple over a cap, headscarf or wide headband and that shows the throat	Decorated headband worn under veil or wimple [RICH] Open faced veil (>1150AD)	Headscarves [POOR] Hoods [POOR] Veils with long tails [RICH]	Bareheaded women / teenage girls Obviously dyed hair Makeup Any tie or fillet worn over the head covering Bead necklace Palla
<b>Under Shift</b>	Shift made from linen, ankle length with a bias edged keyhole or oval neck hole Natural Tight sleeves with rucking	Dyed a light colour or bleached Embroidery [RICH]	Different colour square or round facing Dyed a strong colour Short visible shift, just above the ankle [POOR] Annular brooch at throat	Other decoration Visible shift above mid-calf Pleated underdress
<b>Dress</b>	Woollen ankle length dress with keyhole or oval neck hole and loose sleeves to mid forearm Embroidery [RICH]	Norman style dress with droopy sleeves to mid forearm [RICH] Bliaut dress with pelican style sleeve near wrist [RICH] Tight sleeves (>1150AD) Decorated with: - Braid - Tablet weave (1 to 3 colours) - Brocaded tablet weave [RICH] - Embroidery [RICH] - Silk ribbons [RICH]	Lacing or cinching at sides [N] Overdress to mid shin (must be worn with ankle length shift) Tight sleeves (<1150AD) Dress made from linen <i>Decorated hem with a facing, embroidered facing or braid</i> <i>'Decorative' brooch [RICH]</i> <i>Dress to mid forearm and mid shin with no visible under shift [POOR] [R]</i>	Dress above mid-shin Different coloured gores or sleeves Other decoration including chunky wool Hangerocks or oval brooches
<b>Belt &amp; Bags</b>	No belts or girdles	Cloth sash in same material as dress or mantle Leather or cloth satchels or sacks <i>Drawstring pouch</i>	Braided or woven textile girdle (no dangling ends) Hidden leather tie belt Small drawstring or tagged pouches Forged snips in sheath <i>Small knife in sheath</i>	Chunky wool girdle Leather belts with buckles Box pouch Modern snips or scissors
<b>Cloak</b>	Mantles	Cloaks clasped at the chest with disc brooch	Cloak pinned with pin or penannular	Trefoil brooches Equal armed brooches Backtrains Different coloured lining
<b>Legs</b>	Bare legs		Trousers or hose if hidden Leg bindings	
<b>Shoes</b>	Low shoes or ankle boots (to bottom of ankle bone) Bare feet		Nålebound socks Ankle boots (up to top of ankle bone) Foot wraps or sock bags	Tall boots (higher than top of ankle bone) 8 <sup>th</sup> C. or earlier patterns

[R] = Restricted; [RICH] = Thegn / Odalsbondi / Hauldr ; [POOR] = Bonded / Serf / Slave

Regia Anglorum  
1080-1179AD

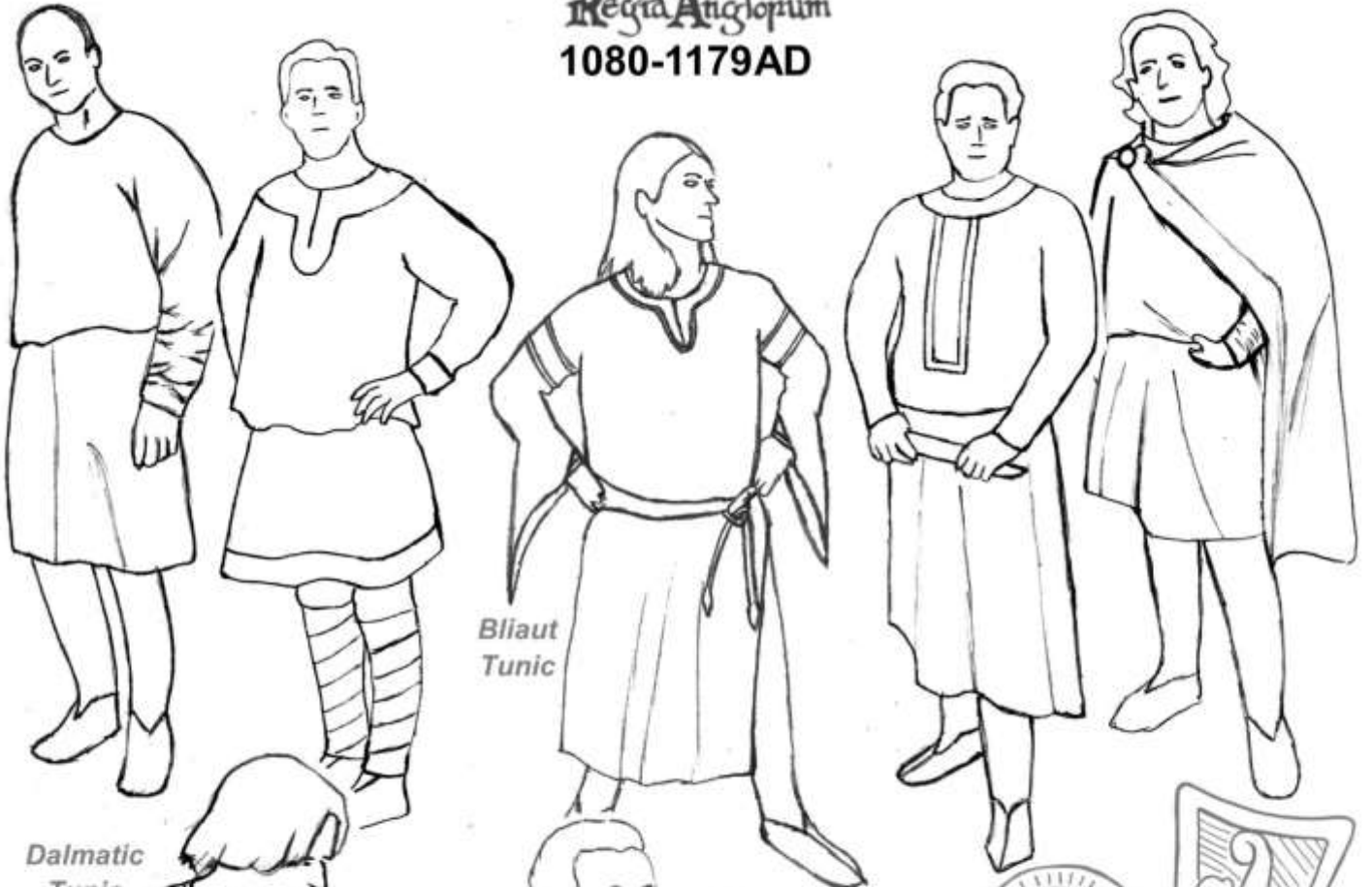

Bliaut  
Tunic

Dalmatic  
Tunic

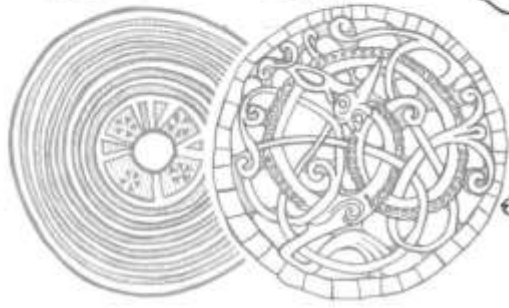

Jewellery at 1:1 scale when printed at A4

**Men's Clothing – Very Late (1080–1179AD)**

	<b>Encouraged (Very Common)</b>	<b>Optional (Less Common)</b>	<b>Allowable (Interpreted or Rare)</b>	<b>Unacceptable</b>
<b>Head</b>	Bare headedness	Woollen hoods Straw hats [POOR][R]	Linen or Leather hoods Skull caps Pointed hats [RICH]	Cloth "Phrygian caps" Obviously dyed hair Bead necklaces Frisian caps Nålebound caps [R] Fur caps
<b>Under Shirt</b>	Natural or bleached shirt made from linen with a bias edged keyhole or oval neck hole Side split	Shirt as outer garment <i>with hem ending up to 2" above the knee</i> Shirt made from wool Dyed a light colour Shirts with skirt gores Front split	Different colour round or square facing Dyed a strong colour Embroidery [RICH] Long under-robe [RICH]	Shirts visible below tunic Other decoration
<b>Tunic</b>	Tunics made of wool Rucked up to knee length with tight rucked sleeves Tunics to just below knee Tunics with faced oval keyhole style neck hole Keyhole or oval neck hole with bias edging Neck hole closed with ties	Tunics made of linen Tunics with faced square keyhole style neck hole Decorated with: - Decorative seams - Braid - Tablet weave (1 to 3 colours) - Brocaded tablet weave [RICH] - Embroidery [RICH] - Silk ribbons [RICH] Facing and decoration around the hem <i>Rucked tunics with hems that end up to 2" above the knee</i>	Shorter tunics un-rucked to knee length Tight sleeves with no rucking Tunic closed with authentic hook & eye Front and back split Long split tunic [RICH] Brooch worn at throat [RICH] Bliaut style tunic [RICH] Dalmatic style tunic over long robe [RICH] Wrist clasps [RICH]	Side split Loose sleeves Different coloured gores or sleeves Shorter than 2" above knee level when unbelted Brooch worn at throat Decorated with: - Chunky wool
<b>Belt &amp; Bags</b>	Buckled leather belts or cloth ties hidden by tunic Small knife in sheath	Split end belts Visible leather belt or cloth tie Leather or cloth satchels or sacks <i>Drawstring pouch</i>	Drawstring or tagged pouches worn on belt	Belts knotted around the buckle Long hanging belt end Belts with metal plates Chunky wool belt Box pouch
<b>Cloak</b>	Rectangular cloaks pinned at shoulder with disc brooch Hanging length from waist to knee	Pinned with metal or bone pin Cloak ribbons [RICH] Edged with different coloured facing Circular style cloaks closed at throat	Cloaks pinned at chest Fur or piled wool lining Pinned with penannular Different coloured linings [RICH][R] Hooded mantle [POOR][R]	Viking jackets Cloaks pinned at hip Different coloured lining Leather or fur cloaks
<b>Legs</b>	Wool trousers or hose tight to legs with leg bindings Trousers or hose with integral feet Bare legs [POOR]	Wool trousers or hose tight to legs with no leg bindings Braies (on their own)	Linen trousers or hose Tight leather hose worn with spurs [RICH] Cross gartering [N] Elaborate ties below knee [RICH]	Viking baggy trousers Loose legged trousers
<b>Shoes</b>	Low shoes or ankle boots (to bottom of ankle bone) Bare feet	Ankle boots (up to top of ankle bone)	Norman style laced tall boots [N] Nålebound socks Foot wraps or sock bags	Other boot styles 8 <sup>th</sup> C. or earlier patterns

[R]= Restricted; [E]= English; [V]= Viking; [N]= Norman; [RICH]= Thegn / Odalsbondi / Hauldr ; [POOR]= Bonded / Serf / Slave

Regia Anglorum  
1080-1179AD

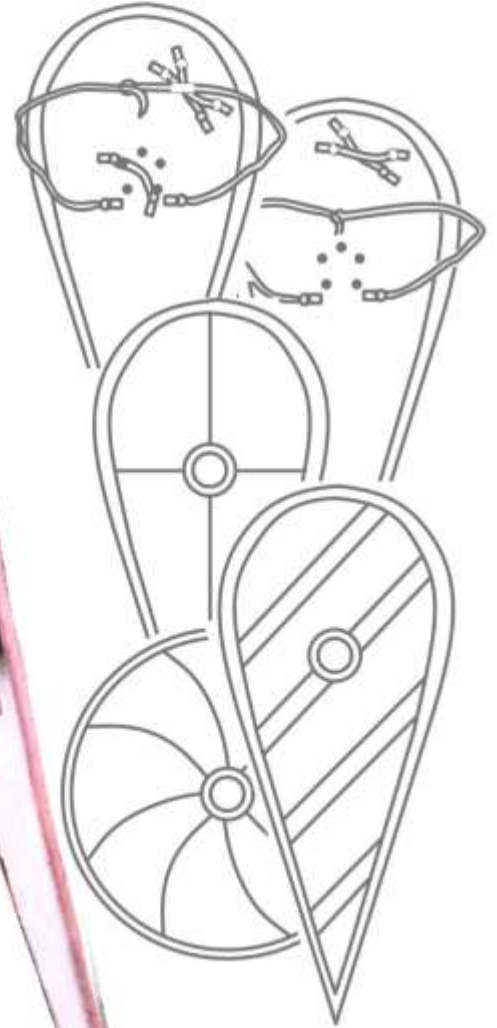
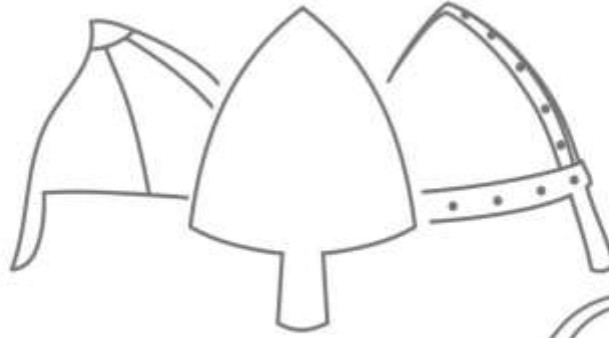
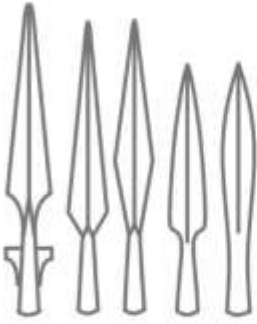



**Wargear – Very Late (1080–1179AD)**

	<b>Encouraged (Very Common)</b>	<b>Optional (Less Common)</b>	<b>Allowable (Interpreted or Rare)</b>	<b>Unacceptable</b>
<b>Helm</b>	Conical or domed helm 'single piece' with or without nasal	Conical helm – riveted panels / welded panels Full face helm (after 1150AD)	Domed helm - riveted Domed helm - small rim Hardened leather cap Helms with aventails	Spectacle helms Boar crested helms Coppergate helms Bucket / kettle helms Great Polish helm
<b>Armour</b>	Mail shirt with integral coif, side closing ventail and long sleeves (no mittens) Front split mail shirt with long sleeves Leather jack, leather or cloth padded gambeson worn under mail 6 - 8mm alternating riveted & welded	Mail leg protection (tube or front face with or without feet) Unsplit long mail shirt Leather jack or leather padded gambeson worn as armour 6 – 8mm riveted	Separate coifs (should be disguised) Side split mail shirt Butted / riveted links up to 10mm Short sleeve mail Unsplit short mail Chest square ventail <i>Cloth padded gambeson worn as armour [R]</i> <i>Simple leather gloves</i> <i>Integral mail mittens</i>	Vandyked mail shirt Splinted arms or legs Lamellar / Scale Cuir Boilli / Plate armour <i>Separate mail covered gloves</i>
<b>Shield</b>	Kite shield with boss Sewn on leather or rawhide edge Painted in a single colour	Flat top kite (after 1150AD) Kite shield without boss Nailed on leather or rawhide edge Painted in a cross or simple stripes Painted in other authentic design [RICH] Painted in up to 3 colours	Flat or lenticular round shield Painted in other simple geometric designs Painted in 4 or more colours [R] Painted with a Bayeux animal	Flat top kite Unbossed round shield Rectangular or oval shields Painted in other art style or design
<b>Spear</b>	1-handed spear Angular shaped heads		<i>2-handed spear or winged spears with blade of 8" – 16" [after 1/1/2017]</i> Leaf shaped heads	Angon
<b>Knife</b>	Double or single edged fighting knives (not seaxes) in vertical sheath Wood handles	Bone handles Decorated knife sheath <i>Seaxes with blades from 7" to 10"</i>	<i>with blades up to 12" [until 1/1/2017]</i> Worked antler handles Sheath horizontally hung Undecorated sheath Composite wood / bone / stone handles [RICH]	Un-sheathed knives Rondel & bollock daggers Unworked antler handles Wooden handles with bark
<b>Sword</b>	Disc, tea cosy and brazil nut pommels on swords Swords on sword belts Composite wooden / leather plain scabbard		C11 <sup>th</sup> sword types Swords on baldrics	Unscabbarded weapons C10th sword types Single edged swords Langseax Decorated scabbards
<b>Other</b>	Broadaxes (Dane axe) Crescent bladed axe <i>Axes hafted with wooden wedges</i>	Mace as a weapon [RICH] Hand axes without beards	Hand axes with beards Leather axe loops Edge protector for axe	Francisca Metal axe rings Flanged mace
<b>Missile</b>	Self-bow with arrows in quivers Bodkin heads Javelins	Crossbows (locking nut)	Re-curve Self-bow Slings	

[R]= Restricted; [E]= English; [N]= Norman; [RICH]= Thegn / Odalsbondi / Hauldr ; [POOR]= Bonded / Serf / Slave

Regia Anglorum  
1180-1215AD

Barbette  
& Open Veil



Magyar  
Sleeve

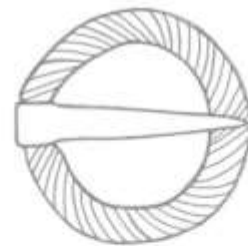
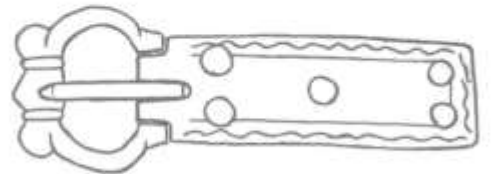
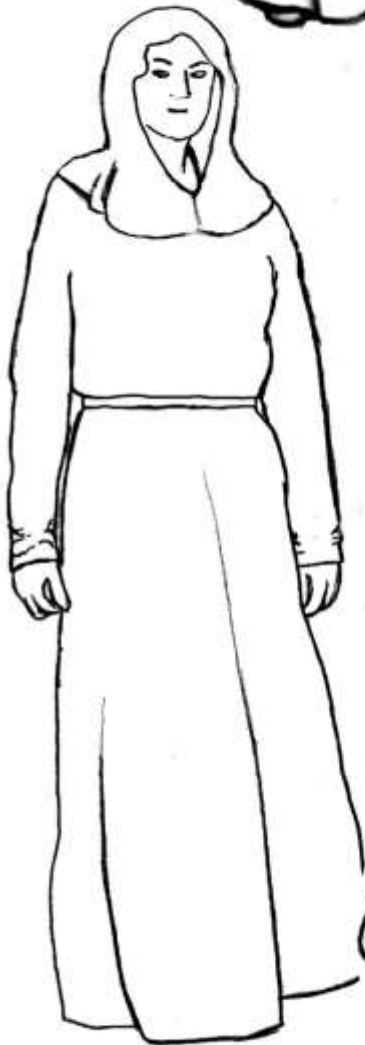

**Women's Clothing – Angevin (1180–1215AD)**

	<b>Encouraged (Very Common)</b>	<b>Optional (Less Common)</b>	<b>Allowable (Interpreted or Rare)</b>	<b>Unacceptable</b>
<b>Head</b>	Veil or wimple over a cap, headscarf or wide headband and that shows the throat Open faced veils	Decorated headband worn under veil or wimple	Headscarves [POOR] Hoods [POOR] Veils with long tails [RICH] Straw hats over veil or wimple [POOR] Barbettes [RICH] [R] <i>Metal fillet over veil [RICH]</i>	Bareheaded women / teenage girls Obviously dyed hair or makeup Tablet or inkle braid headbands Any tie or cloth fillet worn over the head covering Bead necklace Enclosed throat wimples
<b>Under Shift</b>	Shift made from linen, ankle length with a bias edged keyhole or oval neck hole Natural Tight sleeves with rucking	Dyed a light colour or bleached Embroidery [RICH] Annular brooch at throat	Different colour square or round facing Dyed a strong colour Short visible shift, just above the ankle [POOR]	Other decoration Visible shift above mid-calf Pleated underdress
<b>Dress</b>	Woollen ankle length dress with oval or keyhole style neck hole, long sleeved tight to wrist Embroidery [RICH] Magyar sleeves Full skirts to dresses, with some tailoring to body	Looser fitting sleeves Decorated with: - Braid - Tablet weave (1 to 3 colours) - Brocaded tablet weave [RICH] - Embroidery [RICH] - Silk ribbons [RICH]	Overdress to mid shin (must be worn with ankle length shift) [POOR] <i>Dress to mid forearm and mid shin with no visible under shift [POOR] [R]</i> Lacing or cinching at sides Rucked sleeves Dress made from linen <i>'Decorative' brooch [RICH]</i>	Dress above mid-shin Different coloured gores or sleeves Other decoration including inkle braid Hangerocks or oval brooches
<b>Belt &amp; Bags</b>	No belts or girdles Short braided or woven textile girdle	Cloth sash in same material as dress or mantle Leather or cloth satchels or sacks Long braided or woven textile girdle or leather belt with buckle with dangling end to mid shin <i>Drawstring pouch</i>	Small drawstring or tagged pouches Forged snips in sheath <i>Small knife in sheath</i>	Inkle braid girdle Box pouch Modern snips or scissors
<b>Cloak</b>	Cloaks clasped at the chest with disc brooch	Semi-circular cope style cloaks with a tie fastening across chest [RICH]	Cloak pinned with pin or penannular Mantles	Trefoil brooches Equal armed brooches Backtrains Different coloured lining
<b>Legs</b>	Bare legs		Trousers or hose if hidden	
<b>Shoes</b>	Low shoes or ankle boots (to bottom of ankle bone) Bare feet		Nålebound socks Ankle boots (up to top of ankle bone) Taller boots Foot wraps or sock bags	Tall boots (higher than top of ankle bone) 8 <sup>th</sup> C. or earlier patterns

[R] = Restricted; [RICH] = Thegn / Knight / Lord ; [POOR] = Bonded / Serf / Slave

Regia Anglorum  
1180-1215AD

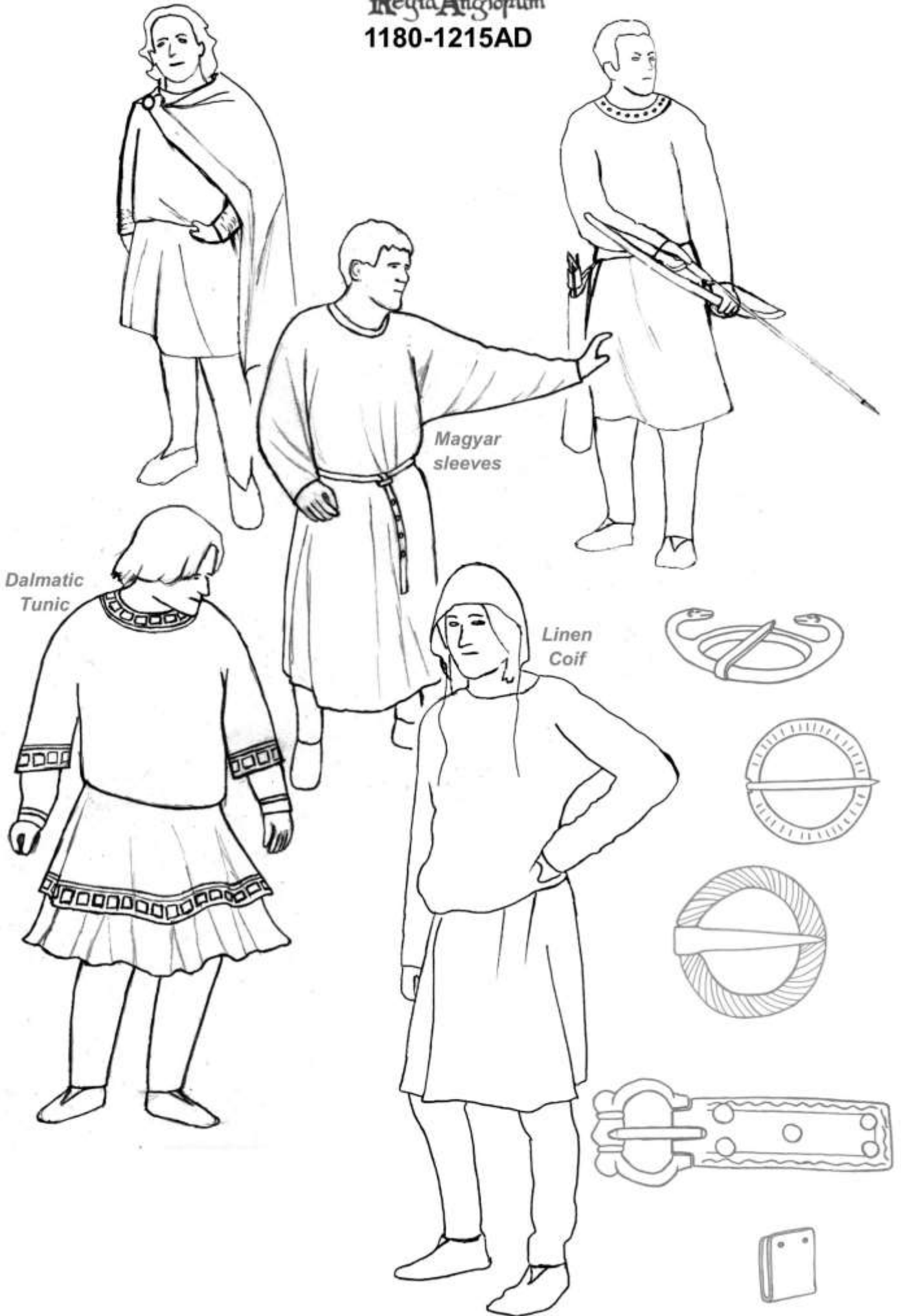



**Men's Clothing – Angevin (1180-1215 AD)**

	<b>Encouraged (Very Common)</b>	<b>Optional (Less Common)</b>	<b>Allowable (Interpreted or Rare)</b>	<b>Unacceptable</b>
<b>Head</b>	Plain linen coifs	Bare headedness Woollen hoods Straw hats (often over a linen coif)	Skull caps Linen or leather hoods	Cloth "Phrygian caps" Obviously dyed hair Bead necklaces Frisian caps Nålebound caps [R] Fur caps
<b>Under Shirt</b>	Natural or bleached shirt made from linen with a bias edged keyhole or oval neck hole Side split	Shirt as outer garment <i>with hem ending up to 2" above the knee</i> Shirt made from wool Dyed a light colour Shirts with skirt gores Front split	Different colour round or square facing Dyed a strong colour Embroidery [RICH] Long robe [RICH]	Shirts visible under tunic Other decoration
<b>Tunic</b>	Tunics made of wool Rucked up to knee length with tight sleeves Tunics with faced oval keyhole style neck hole Keyhole or oval neck hole with bias edging Neck holes closed with ties Split front tunics	Tunics made of linen Tunics with faced square keyhole style neck hole Decorated with: - Decorative seams - Braid - Tablet weave (1 to 3 colours) - Brocaded tablet weave [RICH] - Embroidery [RICH] - Silk ribbons [RICH] Magyar sleeves <i>Rucked tunics with hems that end up to 2" above the knee</i>	Shorter tunics un-rucked to knee length Tight sleeves with rucking Tunic closed with authentic hook & eye Loose sleeves Long split front tunics (calf to ankle length) [RICH] Dalmatic tunic over long robe [RICH]	Side split Loose sleeves Different coloured gores or sleeves Shorter than 2" above knee level when unbelted Brooch worn at throat Decorated with: - Inkle braid - facing, braid or embroidery around the hem
<b>Belt &amp; Bags</b>	Buckled leather belts or cloth ties hidden by tunic Small knife in sheath	Split end belts Visible leather belt or cloth tie Leather or cloth satchels or sacks <i>Drawstring pouch</i>	Drawstring or tagged pouches worn on belt <i>Long hanging belt (possibly with plates)</i> [RICH]	Inkle braid belt Box pouch
<b>Cloak</b>	Rectangular cloaks pinned at shoulder with disc brooch Hanging length from waist to knee	Pinned with metal or bone pin Cloak ribbons [RICH] Edged with different coloured facing Different coloured linings Circular style cloaks closed at throat	Cloaks pinned at chest Fur lining Pinned with penannular Hooded mantle [POOR][R]	Viking jackets Mantles Cloaks pinned at hip Leather or fur cloaks
<b>Legs</b>	Wool hose tight to legs without leg bindings Hose with integral feet Bare legs [POOR]	Braies (on their own)	Linen hose Tight leather hose worn with spurs [RICH] Wool trousers tight to legs with no leg bindings	Leg bindings Viking baggy trousers Loose legged trousers
<b>Shoes</b>	Low shoes or ankle boots (to bottom of ankle bone) Bare feet	Ankle boots (up to top of ankle bone) Mid-calf boots (pull on or spiral laced)	Slipper style shoes [RICH] Nålebound socks Foot wraps or sock bags	Other boot styles 10 <sup>th</sup> C. or earlier patterns

[R] = Restricted; [RICH] = Thegn / Knight / Lord ; [POOR] = Bonded / Serf / Slave

Regia Anglorum  
1180-1215AD



\* Faceplate helmets must be worn with full sleeved hooded mail (or coif & surcoat), kite shield & period sword

**Wargear – Angevin (1180-1215AD)**

	<b>Encouraged (Very Common)</b>	<b>Optional (Less Common)</b>	<b>Allowable (Interpreted or Rare)</b>	<b>Unacceptable</b>
<b>Helm</b>	Flat top faceplate or enclosed helm [K] Conical or Domed helm – ‘single piece’ with or without nasal	Iron ‘hats’ with narrow brim worn over mail hood / linen coif Secret cervelliere Conical or domed helm – riveted or welded panels	Helms with aventails Hardened leather cap Helms without nasals Domed face plate helms [RICH]	Spectacle helms Boar crested helms Coppergate helms Sugar loaf helms Broad brimmed iron ‘hats’
<b>Armour</b>	Mail shirt with integral coif, side closing ventail and long sleeves (with integral mitts) [RICH] [K] Long sleeve front split or unsplit mail shirt to knees Leather jack, leather or cloth padded gambeson worn under mail 6 - 8mm alternating riveted & welded Loose surcoats over long sleeved & hooded mail (1 colour) [K]	Footed mailed leg protection [RICH] [K] Unfooted mailed leg protection [K] Leather jack or leather padded gambeson worn as armour 6 – 8mm riveted Loose surcoats over long sleeved mail with hood / coif (1 or 2 colours); striped designs (possibly with emblem)	Mail byrnies Short sleeved mail Chest square ventail Separate coifs (should be disguised) Side split mail shirt Butted / riveted links up to 10mm Tighter surcoat styles over long sleeved mail with hood / coif (1 or 2 colours) <i>Surcoats with halved or quartered designs</i> <i>Cloth padded gambeson worn as armour [R]</i> <i>Simple leather gloves</i>	Vandyked mail shirt Splinted arms or legs Lamellar / Scale Cuir Boilli / Plate armour Separate mail covered gloves
<b>Shield</b>	Flat top kite [RICH] [K] Heraldry [K] [R] Kite shield without boss Sewn on leather or rawhide edge Painted in a single colour	Kite / flat top kite shield with boss Nailed on leather or rawhide edge Painted in stripes or other repeated geometric design Painted in up to 3 colours	Heater shield [RICH] [K] Round shield [POOR] Painted in quartering or other geometric divisions Painted in 4 or more colours [R] Kite shield painted with zoomorphic design [RICH]	Parallel sided/tower shield Rectangular or oval shields Painted in other art style or design Lenticular shields Target shields
<b>Spear</b>	1-handed spear Angular shaped heads		<i>2-handed spear or winged spears with blade of 8” – 16” [after 1/1/2017]</i> Leaf shaped heads	Angon
<b>Knife</b>	Double or single edged fighting knives (not seaxes) in vertical sheath Wood handles	Bone handles	Worked antler handles Undecorated sheath Composite wood / bone / stone handles [RICH] Seax in vertical sheath	Un-sheathed knives Rondel & bollock daggers Unworked antler handles Wooden handles with bark
<b>Sword</b>	Disc pommels Long straight crossguards Swords on sword belts Composite wooden / leather plain scabbard	Tea cosy / Brazil nut pommels Long, curved crossguards	Boat pommels Swords on baldrics	Unscabbarded weapons C8th & C9th sword types Single edged swords Langseax Decorated scabbards
<b>Other</b>	Broadaxes (Dane axe) Lochaber axe Hand axes without beards <i>Axes hafted with wooden wedges</i>	Mace as a weapon [K] [RICH] Glaives Crescent bladed axes	Axes with beards [POOR] Leather axe loops Edge protector for axe War pick on long shaft Flanged Mace	Francisca Metal axe rings
<b>Missile</b>	Self-bow with arrows in quivers. Bodkin heads Javelins	Crossbows (locking nut)	Re-curve Self-bow Slings Crossbows (rising pin)	

[R] = Restricted; [K] = Knight ; [RICH] = Thegn / Lord ; [POOR] = Bonded / Serf / Slave

# Regia Anglorum Authenticity Guide 2015

## Food - (All Periods)

NOTE: Meant as a helpful and informative guide only, not an authenticity enforced diet! 😊

*This table has been updated with additions from the 'Regia Wic Cookbook' by Helen Mallalieu*

*The country of origin is supplied where reasonably known for RICH items*

	<b>Encouraged (All social classes)</b>	<b>Optional (Free people &amp; RICH )</b>	<b>Allowable (Modern or uncertain items)</b>	<b>Unacceptable (When on show)</b>
<b>Drinks</b>	Water Small Beer (very low alcohol Beer), Cider (Not during public opening times) Whey, Buttermilk Herbal teas (rosehip, mint), Meat teas (Bovril)	Wine Spiced wine [RICH] Mead [RICH] Milk [RICH]	Inauthentic drinks hidden discreetly in authentic vessels	Visible cans / bottles and obvious modern beverages Modern bottles in poorly made bags to 'hide' them Camping Kettles
<b>Cooking</b>	Porridge Stew	Spit roast, Kebabs Baking Frying		
<b>Oils / Salt</b>	Rock salt, Sea salt Dripping, Lard, Suet	Nut oil Olive oil {Mediterranean} [RICH]	Sunflower oil {modern} Vegetable oils	
<b>Sweet</b>		Honey		Sugar, Chocolate, Fudge, Golden syrup,
<b>Preserving</b>	Vinegar / Pickling Salting, Brine Drying (meats, fish, fruit)			Clingfilm Aluminium Foil Tupperware
<b>Bread</b>	Flat unleavened bread, Mixed grain bread Wheat, Rye wholemeal flours Biscuits like rock cakes, birch sap, drop scones / scotch pancakes	Small round granary loaves or rolls Oat, Barley, Spelt wholemeal flours White bread (small amounts) [RICH]	Large loaves {modern} White flour {modern}	Sliced bread Soft baps Tin shaped bread Tiger / giraffe loaves
<b>Grains</b>	Wheat, Rye, Barley, Oat, Spelt Peas, Broad beans, Kidney beans	Lentils {Mediterranean} Chick peas {France} RICH	Buckwheat	Rice Pasta
<b>Vegetables</b>	Beet leaves, Beet root, Cabbage, Carrot (red, black or purple), Celery, Cress, Fennel, Kale, Leek, Lettuce, Marrow, Nettles, Onions, Parsnip, Radish, Rocket, Spinach, Seaweed, Turnip, Watercress, Mushrooms	Cucumber {France} [RICH] Artichoke {Naples} [RICH]	Orange carrots {modern}	Asparagus Swede Potatoes Crisps & Chips Tomatoes Squashes, Courgettes

## Regia Anglorum Authenticity Guide 2015

	<b>Encouraged (All social classes)</b>	<b>Optional (Free people &amp; RICH )</b>	<b>Allowable (Modern or uncertain items)</b>	<b>Unacceptable (When on show)</b>
<b>Herbs</b>	Garlic, Mint, Dill , Parsley, Horseradish, Black mustard, Sage, Chamomile, Tansy, Sweet Cecily, Sorrel, Alexanders,	Chervil, Rosemary, Thyme, Jarrow, Mustard  Basil {Med.}, Lavender {Med.}, Aniseed {Med.}, Coriander {Med.}, Cypress Root, Liquorice {Med.} [RICH]		Visible stock cubes
<b>Spices</b>		Black Cumin, Cardamorn, caraway, cassia, cinnamon, Clove, Cumin, fenugreek, ginger, Pepper, saffron. [RICH]		
<b>Meat</b>	None Beef bone marrow Offal, Tongue Mutton, Beef (cheap cuts), Chicken, Duck, Goose, Pigeons, Pork, Goat, Hare Salted or cured meat	Beef (prime cuts), Lamb, Venison, Game, Wild Boar, Peacock [RICH]  Sausages, Blood sausages Horse [V - heathen]	Sliced meats (ham, chicken or beef)  Rabbit (as a baby hare)  Burgers	Processed meats in unnatural shapes (square). Turkey Scotch eggs Chocolate eggs (damn...)
<b>Fish</b>	Eel & Fresh water fish Salted or cured fish Oysters, cockles, mussels	Salt water fish Whale (on your head be it) Clams	Lobsters / Crayfish Crabs	Sea food sticks
<b>Dairy</b>	Butter, Buttermilk, Whey Soft or cottage cheese Sheep or Goats Milk, Sheep or Goats cheese Chicken, Duck, Goose eggs Wild bird eggs (now illegal)	Cream Hard cheese (please reshape so that it's not square) [RICH] Salted cheese Cow's Milk Blue cheese [RICH]	Smoked cheese Cheese with fruit and nuts in it	Ice cream Wax coated cheeses with a rind (Brie, Mozzarella, Parmesan) Coloured cheese (Red Leicester)
<b>Fruits</b>	Apples, Pears, Blackberries, Strawberries, Mulberry, Plums, Peaches	Grapes, Raspberries, Cherries, Sloes, Bilberries, Myrtle  Dried fruit (Dates, Figs, Raisins, prunes) [RICH]	Quince [RICH]	Citrus fruits Exotic fruits
<b>Nuts / Seeds</b>	Hazelnuts, Sweet chestnut, Beech masts/nuts	Walnuts [RICH], Almonds [RICH] Poppy seeds		Peanuts, Cashews, Pistachio, salted nuts

[R]= Restricted; [E]= English; [V]= Viking; [N]= Norman; [RICH]= Thegn / Odalsbondi / Hauldr ; [POOR]= Bonded / Serf / Slave



  
**Regia Anglorum**  
**793-1100AD**

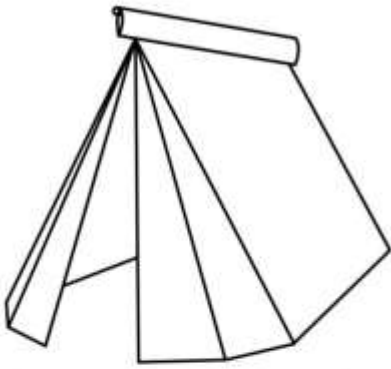

*Saxon tent - end opening  
(Encouraged)*

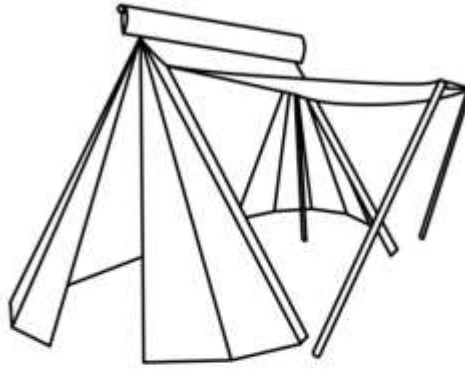

*Saxon tent - side opening  
(Allowable)*

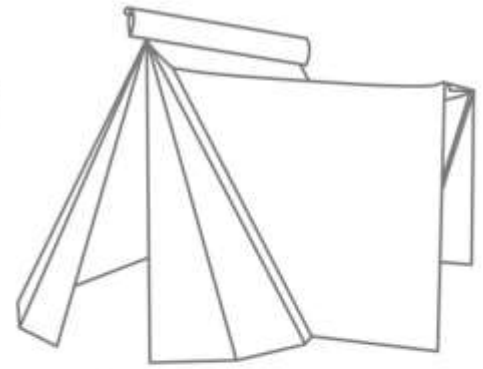

 *Saxon tent - with porch  
(Unacceptable)*

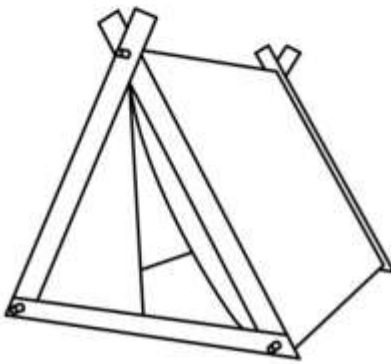

*Viking tent - end opening  
(<980AD Optional,  
>980AD Allowable)*

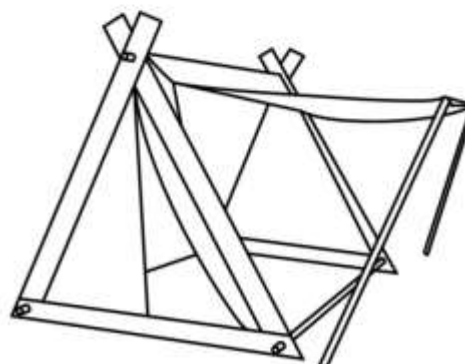

*Viking tent - side opening  
(Allowable)*

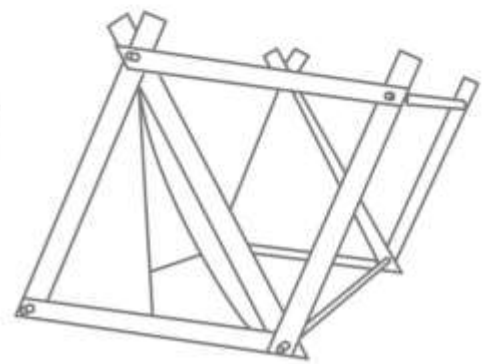

 *Viking tent - framed side  
opening (Unacceptable)*

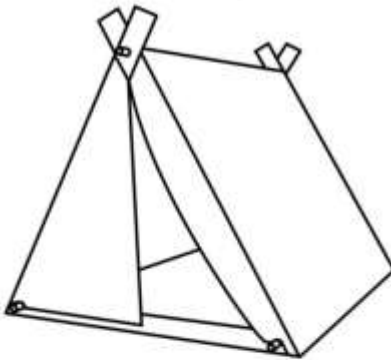

*Viking tent - end opening  
(<980AD Optional,  
>980AD Allowable)*

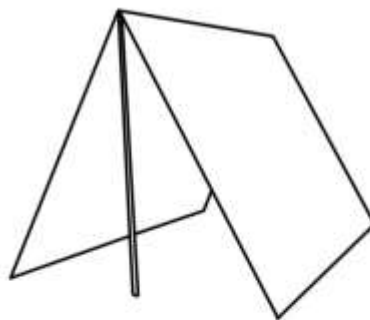

*Simple tent cover  
(Allowable)*

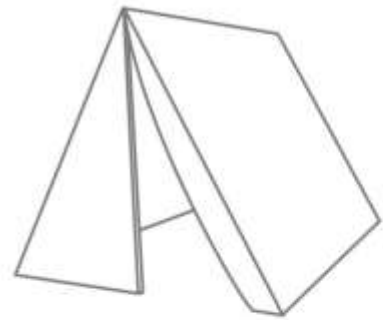

 *Wedge tent  
(Unacceptable)*



*Ecclesiastical Bell tent  
(Optional - Ecclesiastical only)*



 *Walled Bell tent  
(Unacceptable)*

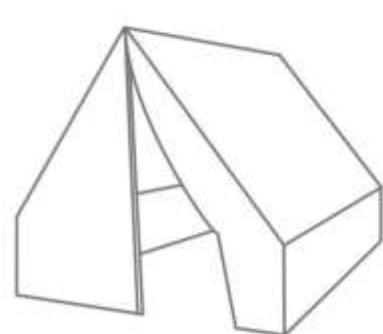

 *Walled Roman (Scout) tent  
(Unacceptable)*

**Wic Equipment - (All Periods)**

	<b>Encouraged (Very Common)</b>	<b>Optional (Less Common)</b>	<b>Allowable (Interpreted or Rare)</b>	<b>Unacceptable</b>
<b>Structures</b>	End opening Saxon style tents Canvas made from linen or wool Woodwork made from painted (single colour) or unpainted native woods Wooden tent pegs Bast and withies as rope Wattle fencing	End opening Viking style tents pre-980AD [V] Simple fire-pit covers Canvas painted in two coloured stripes [approval required] Ecclesiastical Bell Tent Hemp rope	End opening Viking style tents post 980AD [V] Complex fire-pit covers Side opening tents Sash cord as rope Handmade iron or antler tent pegs <i>Cotton, hemp or leather canvas</i> Painted (single colour) pine woodwork	Roman / medieval style tents Modern metal tent pegs Metal eyelets Woodwork made from unpainted pine Manmade fibre rope/cord Obvious metal collars Visible ground sheets or modern bedding
<b>Furniture</b>	Low benches, stools & tables Made from ash, oak, beech, birch or native other woods Clench nails Furs, roggs, simple rugs as floor covering	Wooden framed beds Painted woodwork Waist height tables with 4 legs <i>Tall benches at modern sitting height</i> Table cloths [RICH] Curtains	Folding chairs Chairs with backs Pine furniture Trestle tables Wood or metal perimeter posts and rope	Modern round headed nails Tongue and groove boards Visible plywood, chipboard or MDF Covered modern chairs Dovetail joints

[R]= Restricted; [E]= English; [V]= Viking; [N]= Norman; [RICH]= Thegn / Odalsbondi / Hauldr ; [POOR]= Bonded / Serf / Slave

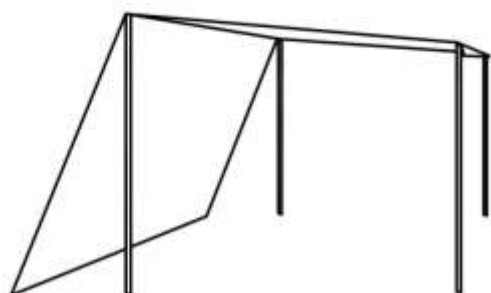

*Simple work shelter  
(Encouraged)*



*Raised work shelter  
(Optional)*

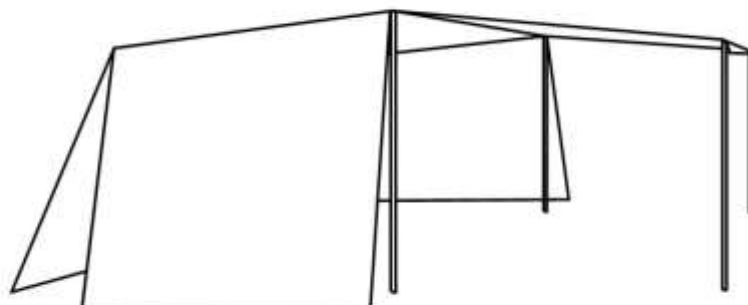

*Enclosed work shelter  
(Optional)*

**Wic Equipment Continued- (All Periods)**

	<b>Encouraged (Very Common)</b>	<b>Optional (Less Common)</b>	<b>Allowable (Interpreted or Rare)</b>	<b>Unacceptable</b>
<b>Storage</b>	Pottery jugs Chests Buckets with wooden bands Small wooden boxes with metal hinges Barrels / Casks with withy bands Round or oval hazel baskets with bark Wooden bottomed baskets	Band (bark) boxes Buckets with metal bands [V] Willow, birch or bramble baskets with bark Reed baskets Wooden boxes Linen or wool sacks and bags	Iron S hooks Linen, wool or leather bags Inauthentic items fully concealed with linen or wool String net bags Square baskets Baskets with simple lids	Bleached, stripped bark or dyed wicker baskets Bamboo or sea-grass baskets Terracotta pottery Modern pine boxes or chests
<b>Cooking</b>	Earthenware pots and leather cooking vessels Wooden ladles and spatulas Soapstone bowls for cooking [V] Fire extinguisher hidden in red bag	Simple iron or wood fire-pit boxes Iron cauldrons, trivets, skillets or tripods [RICH] Iron ladles, spits, forks Bellows Iron S link chain	Complex iron or wood fire-pit boxes Brass or copper cauldrons [RICH] Hanging griddle Ring handled pans Iron O link chain	Modern style frying pans, saucepans or kettles Roman style cookers Firelighters Terracotta pottery
<b>Eating</b>	Wooden bowls and drinking bowls Drinking horns Small knives Spoons of wood or bone	Wooden cups Pottery cups and bowls Glass beakers [RICH] Dough troughs	Horn spoons & beakers 2 pronged forks Wooden plates or platters Persian style cup [V] [R] Pottery or leather costrels	Glass claw beakers Pottery plates 3 or 4 pronged forks Ceramic or glass bottles or jars
<b>Other Items</b>	Oil or wax filled lamps Tallows Wooden Tafl / gaming boards Clay or wooden gaming pieces First aid kit in green bag Antler or bone combs Quiet, well behaved children who listen to their parents (worth a try...)	Beeswax dipped candles [RICH] Leather / hide rope or cord Leather Tafl / gaming boards Glass or amber gaming pieces [RICH] Leather bound books [RICH] Traders scales Leather balls Toy wooden animals Wooden or bone flutes Lyres D-shaped harps [E][N] Box cut pipes [V] Hazel woven eel traps	Metal bowl oil lamps and stands Goat or cow vellum [RICH] Sheepskin parchment [RICH] Runic carving – Younger or Anglo-Frisian futharks [Rare] Simple children's dolls Toy wooden & leather wargear Blowing horns Portable altars [RICH][rare]	Modern wax candles Chess sets Shuttered lanterns Vellum screened lanterns Obvious paper 'parchment' Runic carving – Elder, 'Armanen' or Tolkienesque futharks <i>The number zero and Arabian numerals</i> Regia members not in kit behind ropeline Mobile phones left switched on Radios / iPlayers etc. Tardis or similar Chrononautical devices

[R]= Restricted; [E]= English; [V]= Viking; [N]= Norman; [RICH]= Thegn / Odalsbondi / Hauldr ; [POOR]= Bonded / Serf / Slave

# Timeline

Note: All date ranges are approximate and are for guidance only.

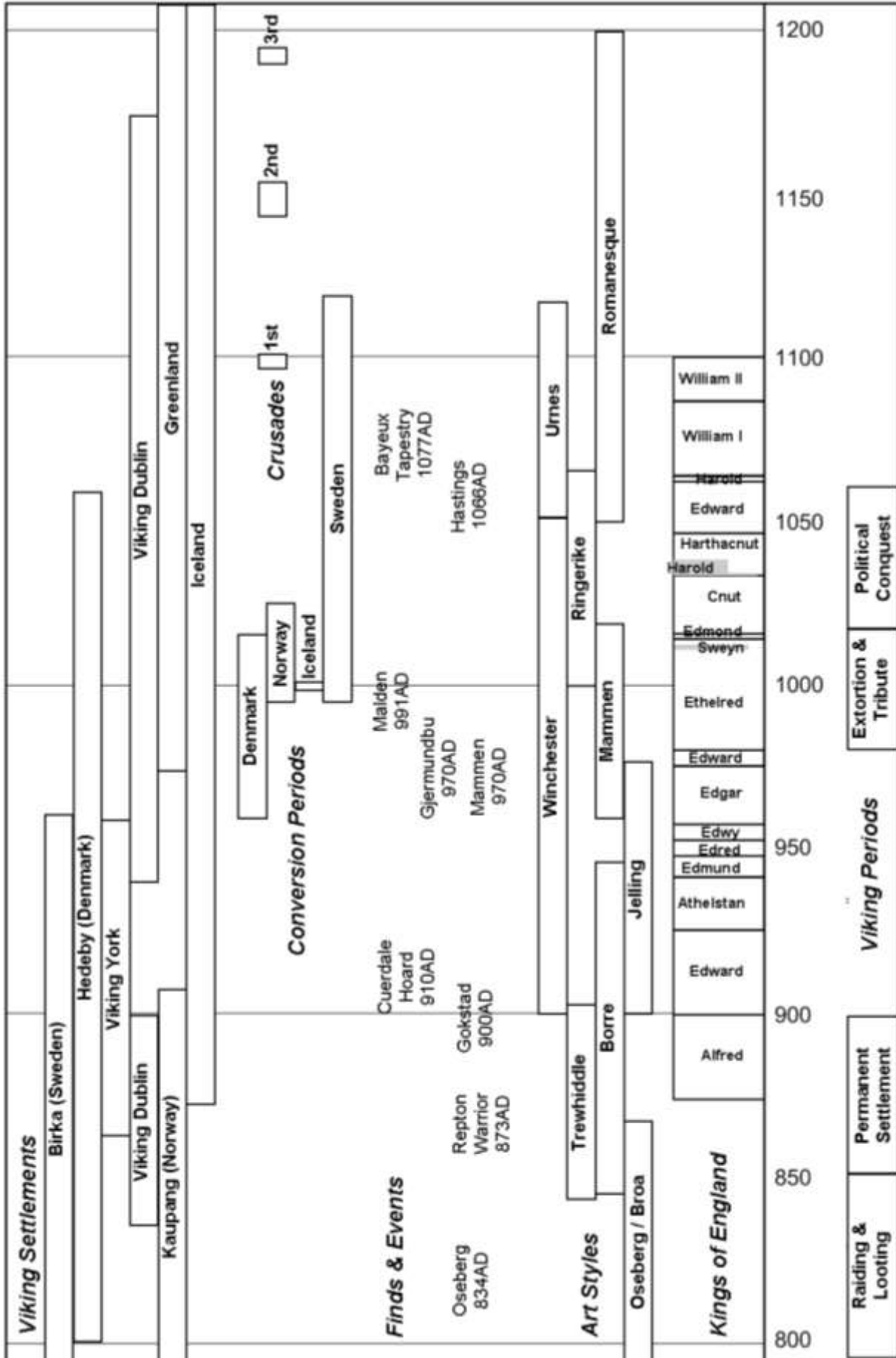



Location images from Wychurst—Regia's solely owned fortified Manor  
Find out more from our website: [www.regia.org](http://www.regia.org)

For info about the society's activities please contact Kim Siddorn: 9 Durleigh Close, Headley Park, Bristol, BS13 7NQ.  
[kim.siddorn@blueyonder.co.uk](mailto:kim.siddorn@blueyonder.co.uk)